

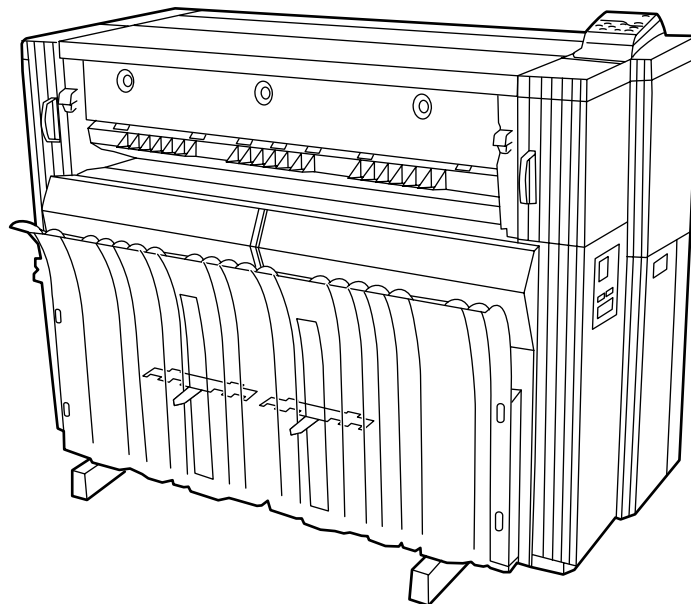

Wide Format Printer
Operation Guide

KM-P4845w
KM-P4850w



Please read the Operation Guide before using the printer.
Keep it in the designated location for easy reference.

As an ENERGY STAR Partner, KYOCERA MITA AMERICA, INC. has determined that this product meets the ENERGY STAR guidelines for energy efficiency.

* ENERGY STAR is a U.S. registered mark.

NOTE

- This Operation Guide applies to models KM-P4845w and KM-P4850w. For the purposes of this guide, KM-P4845w is a **2.6 ppm** (prints per minute) **printer** (36" x 48" size) while KM-P4850w is a **3 ppm printer** (36" x 48" size).
- This Operation Guide contains content for both the inch and metric specification models of the printer. When messages displayed on the printer's display differ only in their capitalization, this guide uses the message from the inch specification model of the printer. When there are other differences, the metric version of the message is included in parentheses.

All rights reserved. No part of this material may be reproduced or transmitted in any form or by any means, electronic or mechanical, including photocopying, recording or by any information storage and retrieval system, without permission in writing from the Publisher.

Legal Restriction On Copying

- It may be prohibited to copy copyrighted material without permission of the copyright owner.
- It is prohibited under any circumstances to copy domestic or foreign currencies.
- Copying other items may be prohibited.

Please read this Operation Guide before using the printer. Keep it close to the printer for easy reference.

The sections of this guide and parts of the printer marked with symbols are safety warnings meant to protect the user, other individuals and surrounding objects, and ensure correct and safe usage of the printer. The symbols and their meanings are indicated below.

 **DANGER:** Indicates that serious injury or even death will very possibly result from insufficient attention to or incorrect compliance with the related points.

 **WARNING:** Indicates that serious injury or even death may result from insufficient attention to or incorrect compliance with the related points.

 **CAUTION:** Indicates that personal injury or mechanical damage may result from insufficient attention to or incorrect compliance with the related points.

Symbols

The \triangle symbol indicates that the related section includes safety warnings. Specific points of attention are indicated inside the symbol.

 [General warning]

 [Warning of danger of electrical shock]

 [Warning of high temperature]

The \odot symbol indicates that the related section includes information on prohibited actions. Specifics of the prohibited action are indicated inside the symbol.

 [Warning of prohibited action]

 [Disassembly prohibited]

The \bullet symbol indicates that the related section includes information on actions which must be performed. Specifics of the required action are indicated inside the symbol.

 [Alert of required action]

 [Remove the power plug from the outlet]

 [Always connect the printer to an outlet with a ground connection]

Please contact your service representative to order a replacement if the safety warnings in this Operation Guide are illegible or if the guide itself is missing. (fee required)

Trademark Information

- Microsoft, Windows, Windows NT and Internet Explorer are registered trademarks of Microsoft Corporation of America and other countries.
- WINDOWS ME is a trademark of Microsoft Corporation of America.
- Adobe, Acrobat and PostScript are registered trademarks of Adobe Systems Incorporated.
- Ethernet is a registered trademark of Xerox Corporation.
- IBM and IBM PC-AT are trademarks of International Business Machines Corporation of America.
- Macintosh, MacOS, AppleTalk and TrueType are registered trademarks of Apple Computer, Inc.
- HP-GL, HP-GL2 and HP-RTL are registered trademarks of Hewlett-Packard Company.
- AutoCAD is a registered trademark of Autodesk, Ltd.

All other company and product names contained in this Operation Guide are trademarks or registered trademarks of their respective companies. The designations TM and © will not be used in this guide.

About This Operation Guide

There are two parts to this guide:

- Operation Guide (this booklet)

Contains explanations of content related to setup procedure, printer operation, configuration, and troubleshooting.

- Functions Edition (On-Line Manual)

Contains explanations on operation from your computer such as how to use related software applications.

The Functions Edition (On-Line Manual) is prepared as a PDF (Portable Document Format) file on the CD-ROM that is included with the printer. Adobe Acrobat Reader 4.0 software is required in order to read this On-Line Manual.

Reading the Functions Edition (On-Line Manual) for This Machine

(1) Windows

1. Insert the CD-ROM that is included with the printer into the CD-ROM drive of your computer.
2. Click on [Documentation] under [Main Menu] on the left side of the screen shown below.
 - * If this screen doesn't appear after you insert the CD-ROM, open the CD-ROM window to access its contents and double-click on the [setup.exe] file.



3. Click on [Operation Manuals] and then on [KM-P4845w/P4850w].

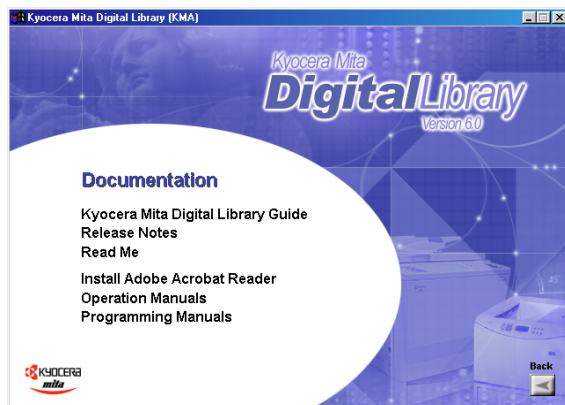

4. Click on [Functions Manual]. Acrobat Reader will start up and the Functions Edition (On-Line Manual) will open.

(2) Macintosh

1. Insert the CD-ROM that is included with the printer into the CD-ROM drive of your computer.
2. Double-click on the icon for the CD-ROM disk, and then double-click [Welcome.pdf] for the shown window. The Kyocera Mita Digital Library screen will appear.

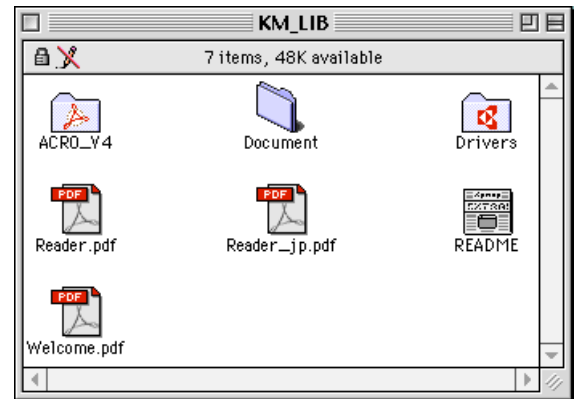

3. Click on [the available printer product name] for the shown screen.
The selected printer's Online Manual will appear.

Setting Up the Printer

Configuring the Printer

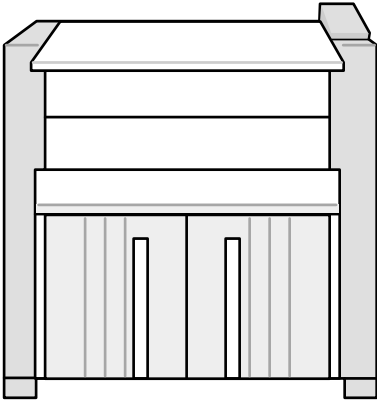

① Network Settings

[Configuring the IP Address, etc.] **Page 3-2**

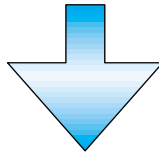

Configuring Your Computer



② Name Settings

[Changing the Computer (Device) and Host Names] **Page 3-4**

③ Installing the Printer Driver

(Refer to the Functions Editor [On-Line Manual].)

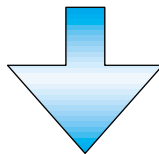

Printer Set-Up is Complete!

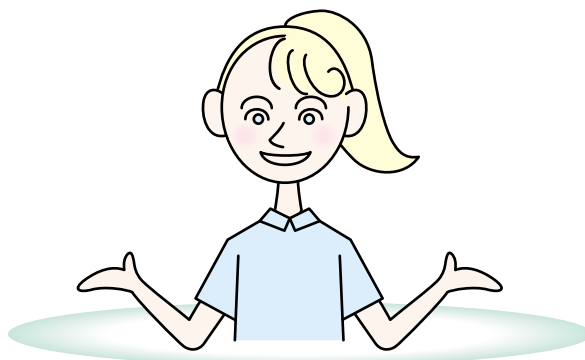

Options

■ <Roll unit>

To add a paper source.

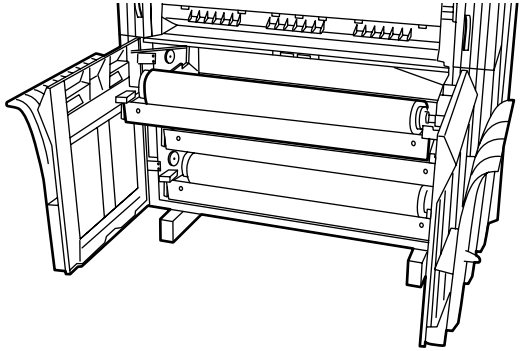

■ <Scanner unit>

To use this machine as a scanner or a copier.

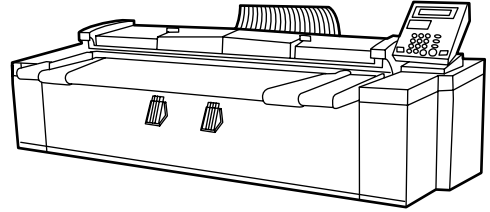

■ <Key counter>

To count the number of sheets output.

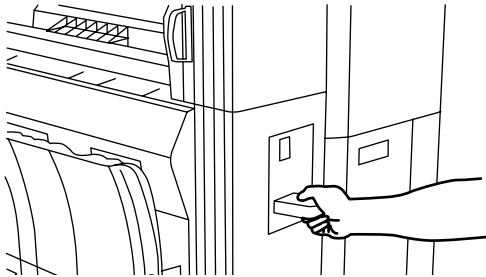

<System diagram with options installed>

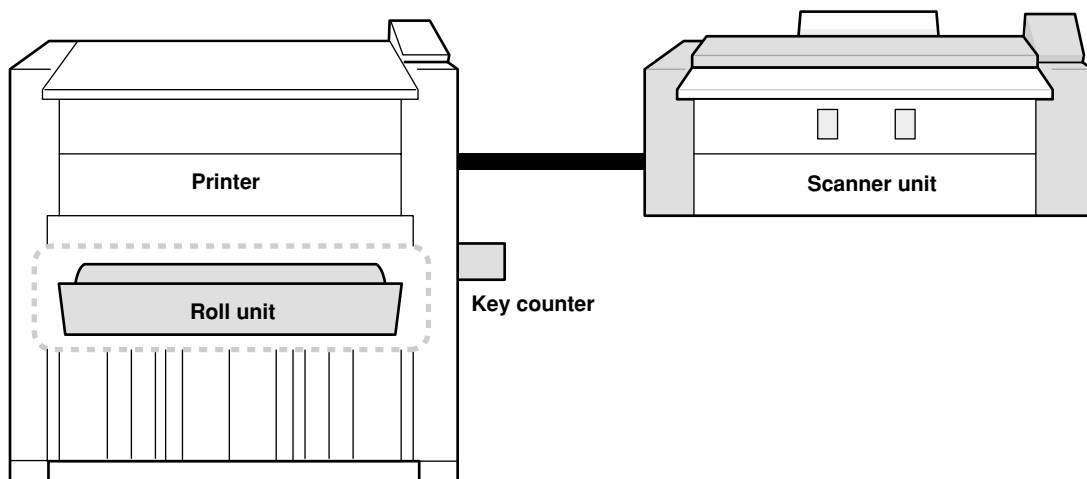





Table of Contents

Trademark Information	i	
About This Operation Guide	i	
Reading the Functions Edition (On-Line Manual) for This Machine	ii	
Setting Up the Printer	iii	
Options	iv	
CHAPTER 1		
IMPORTANT! PLEASE READ FIRST. .	1-1	
 CAUTION LABELS	1-1	
 INSTALLATION PRECAUTIONS	1-2	
 PRECAUTIONS FOR USE	1-3	
CHAPTER 2		
PRIOR TO SET-UP	2-1	
1. Names of Parts	2-1	
(1) Main Body	2-1	
(2) Operation Panel	2-4	
2. Included Software	2-5	
3. Required Items	2-5	
4. Energy Saver Function	2-6	
6. Auto Shutoff Function	2-6	
CHAPTER 3		
GETTING READY FOR PRINTING	3-1	
1. Setup	3-1	
(1) System Configuration	3-1	
(2) Procedures	3-2	
2. Paper	3-6	
(1) Paper Type	3-6	
(2) How to Set a Paper Roll	3-7	
(3) Dew prevention heater	3-9	
(4) How to Use the Paper Tray Support Plate	3-9	
CHAPTER 4		
PRINTER OPERATION	4-1	
1. Basic printing	4-1	
2. Printing with manually fed media	4-2	
3. Making a Test Print	4-3	
4. Canceling Printing	4-4	
5. Resetting the printer	4-5	
CHAPTER 5		
MANAGEMENT AND SETTING	5-1	
1. Machine Default	5-1	
(1) List of Machine Settings	5-1	
(2) Configuring Machine Setting	5-4	
2. Printer Settings	5-11	
(1) List of Printer Settings	5-11	
3. Language Switching	5-12	
CHAPTER 6		
TROUBLESHOOTING	6-1	
1. If One of These Messages is Displayed... ..	6-1	
2. Replenishing the Toner	6-3	
3. Replacing the Waste Toner Tank	6-5	
4. Countermeasures against Call for service Message	6-6	
5. When Paper Jams	6-7	
(1) Jam Location Display	6-7	
(2) Cautions	6-7	
(3) Removal Procedure	6-7	
6. Troubleshooting	6-11	
CHAPTER 7		
SPECIFICATIONS	7-1	

CHAPTER 1 IMPORTANT!

PLEASE READ FIRST.

CAUTION LABELS

Caution labels have been attached to the printer at the following locations for safety purposes. BE SUFFICIENTLY CAREFUL to avoid fire or electric shock when removing a paper jam.

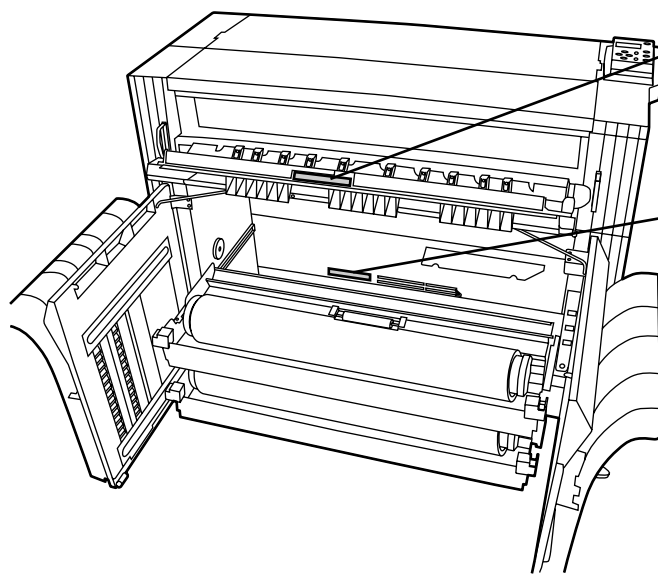

Label 1
High temperature inside. Do not touch parts in this area, because there is a danger of getting burned.....



Label 2 (Inch specification only)
High temperature inside. Do not touch parts in this area, because there is a danger of getting burned.....



Label 3
High temperature inside. Do not touch parts in this area, because there is a danger of getting burned.....

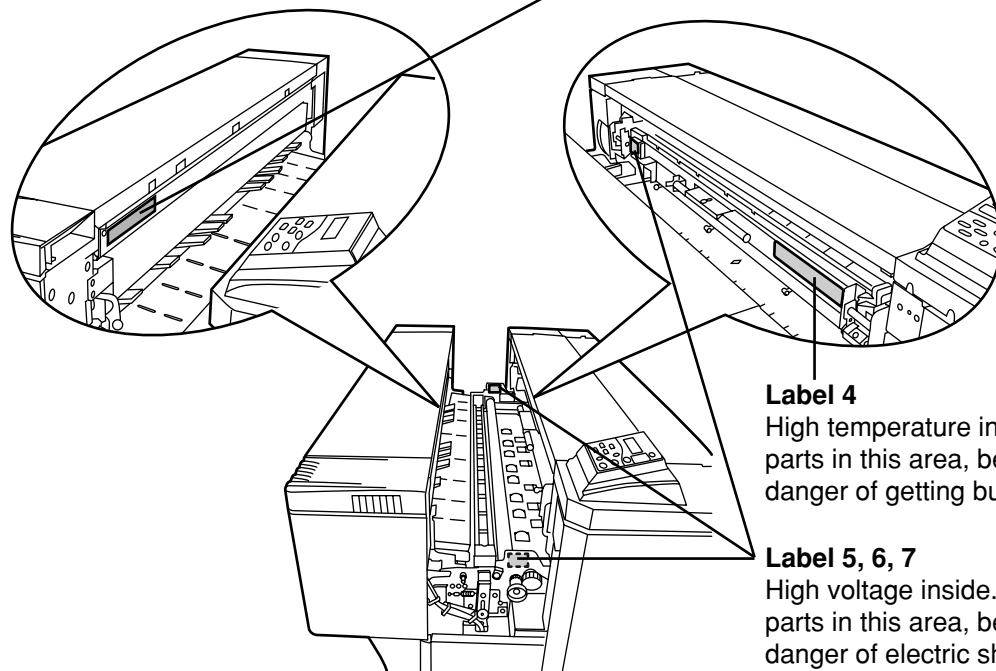

Label 4
High temperature inside. Do not touch parts in this area, because there is a danger of getting burned.....



Label 5, 6, 7
High voltage inside. NEVER touch parts in this area, because there is a danger of electric shock.



NOTE: DO NOT remove these labels.

INSTALLATION PRECAUTIONS

■ Environment

CAUTION

- Avoid placing the printer on or in locations which are unstable or not level. Such locations may cause the printer to fall down or fall over. This type of situation presents a danger of personal injury or damage to the printer.
- Avoid locations with humidity or dust and dirt. If dust or dirt become attached to the power plug, clean the plug to avoid the danger of fire or electrical shock.
- Avoid locations near radiators, heaters, or other heat sources, or locations near flammable items, to avoid the danger of fire.
- To keep the printer cool and facilitate changing of parts and maintenance, allow access space as shown below.
Leave adequate space, especially around the left right and rear covers, to allow air to be properly ventilated out of the printer.

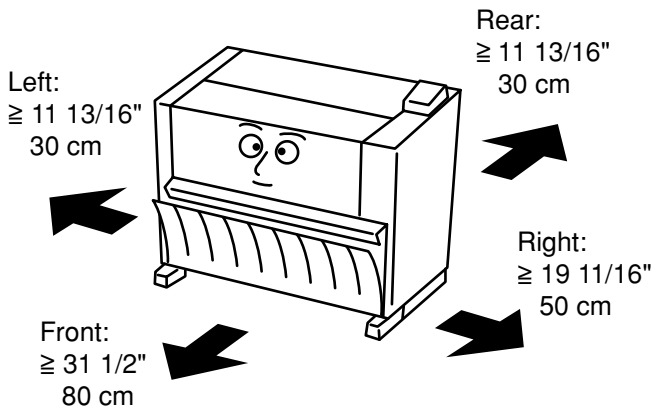

- Always use the caster stoppers to stabilize the printer once it is in place to keep it from moving and/or falling over and causing injury.



Other precautions

- Adverse environmental conditions may affect the safe operation and performance of the printer. Install in an air-conditioned room (recommended room temperature: around 68°F [20°C], humidity: around 65%RH) and avoid the following locations when selecting a site for the printer.
 - Avoid locations near a window or with exposure to direct sunlight.
 - Avoid locations with vibrations.
 - Avoid locations with drastic temperature fluctuations.
 - Avoid locations with direct exposure to hot or cold air.
 - Avoid poorly ventilated locations.

- If the floor is delicate against casters, when this product is moved after installation, the floor material may be damaged.
- During printing, some ozone is released, but the amount does not cause any ill effect to one's health. If, however, the printer is used over a long period of time in a poorly ventilated room or when making an extremely large number of copies, the smell may become unpleasant. To maintain the appropriate environment for printing work, it is suggested that the room be properly ventilated.

■ Power supply/Grounding the printer

WARNING

- DO NOT use a power supply with a voltage other than that specified. Avoid multiple connections in the same outlet. These types of situations present a danger of fire or electrical shock.
- Plug the power cord securely into the outlet. If metallic objects come in contact with the prongs on the plug, it may cause a fire or electric shock.
- Always connect the printer to an outlet with a ground connection to avoid the danger of fire or electrical shock in case of an electric short. If an earth connection is not possible, contact your service representative.



Other precautions

- Connect the power plug to the closest outlet possible to the printer.
- The power supply cord is used as the main disconnect device. Ensure that the socket/outlet is located/installed near the equipment and is easily accessible.

■ Handling of plastic bags

WARNING











- Keep the plastic bags that are used with the printer away from children. The plastic may cling to their nose and mouth causing suffocation.









PRECAUTIONS FOR USE

■ Cautions when using the printer

WARNING

- DO NOT place metallic objects or containers with water (flower vases, flower pots, cups, etc.) on or near the printer. This type of situation presents a danger of fire or electrical shock should they fall inside. 
- DO NOT remove any of the covers from the printer as there is a danger of electrical shock from high voltage parts inside the printer. 
- DO NOT damage, break or attempt to repair the power cord. DO NOT place heavy objects on the cord, pull it, bend it unnecessarily or cause any other type of damage. These types of situations present a danger of fire or electrical shock. 
- NEVER attempt to repair or disassemble the printer or its parts as there is a danger of fire, electrical shock or damage to the laser. 
- If the printer becomes excessively hot, smoke appears from the printer, there is an odd smell, or any other abnormal situation occurs, there is a danger of fire or electrical shock. Turn the main switch OFF () immediately, remove the power plug from the outlet and contact your service representative. 
- If anything harmful (paper clips, water, other fluids, etc.) falls into the printer, turn the main switch OFF () immediately. Next, remove the power plug from the outlet to avoid the danger of fire or electrical shock. Then contact your service representative. 
- DO NOT remove or connect the power plug with wet hands, as there is a danger of electrical shock. 
- ALWAYS contact your service representative for maintenance or repair of internal parts. 

CAUTION

- DO NOT pull the power cord when removing it from the outlet. If the power cord is pulled, the wires may become broken and there is a danger of fire or electrical shock. (ALWAYS grasp the power plug when removing the power cord from the outlet.) 
- ALWAYS remove the power plug from the outlet when moving the printer. If the power cord is damaged, there is a danger of fire or electrical shock. 
- If the printer will not be used for a short period of time (overnight, etc.), turn the main switch OFF (). If it will not be used for an extended period of time (vacations, etc.), remove the power plug from the outlet for safety purposes during the time the printer is not in use. 
- When moving the printer, turn the leveler bolts to keep them away from the floor. 
- For safety purposes, ALWAYS remove the power plug from the outlet when performing cleaning operations. 
- If dust accumulates within the printer, there is a danger of fire or other trouble. It is therefore recommended that you consult with your service representative in regard to cleaning of internal parts. This is particularly effective if accomplished prior to seasons of high humidity. Consult with your service representative in regard to the cost of cleaning the internal parts of the printer. 





PRECAUTIONS FOR USE

Other precautions

- DO NOT place heavy objects on the printer or cause other damage to the printer.
- DO NOT open the front cover, turn off the main switch, or pull out the power plug during printing.
- When lifting or moving the printer, contact your service representative.
- Do not touch electrical parts, such as connectors or printed circuit boards. They could be damaged by static electricity.
- DO NOT attempt to perform any operations not explained in this handbook.
- CAUTION : Use of controls or adjustments or performance of procedures other than those specified herein may result in hazardous radiation exposure.

■ Cautions when handling consumables

CAUTION

- DO NOT attempt to incinerate the toner containers or the waste toner tank. Dangerous sparks may cause burns. 
- Keep the toner containers and the waste toner tank out of the reach of children. 
- If toner happens to spill from the toner containers or the waste toner tank, avoid inhalation and ingestion, as well as contact with your eyes and skin. 
 - If you do happen to inhale toner, move to a place with fresh air and gargle thoroughly with a large amount of water. If coughing develops, contact a physician.
 - If you do happen to ingest toner, rinse your mouth out with water and drink 1 or 2 cups of water to dilute the contents of your stomach. If necessary, contact a physician.
 - If you do happen to get toner in your eyes, flush them thoroughly with water. If there is any remaining tenderness, contact a physician.
 - If toner does happen to get on your skin, wash with soap and water.
- DO NOT attempt to force open or destroy the toner containers or the waste toner tank. 

Other precautions

- After use, ALWAYS dispose of the toner containers and the waste toner tank in accordance with Federal, State and Local rules and regulations.
- Store all consumables in a cool, dark location.
- If you will not be using the printer for a prolonged period of time, remove all paper from the drawer(s) and the multi-bypass tray and seal in its original packaging.

CHAPTER 2 PRIOR TO SET-UP

1. Names of Parts

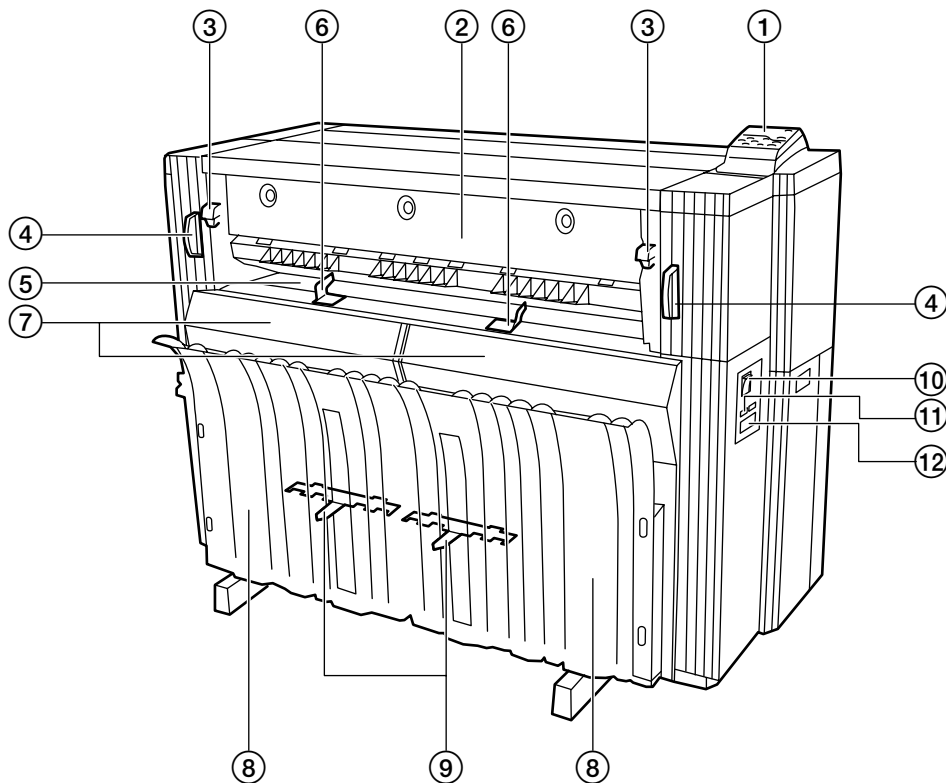

(1) Main Body

- ① Operation panel
Use to make settings in the printer.
- ② Ejection cover
Open in case of a paper jam.
- ③ Ejection release lever
Operate this lever in case of a paper jam.
- ④ Printer body release lever
Operate this lever in case of a paper jam.
- ⑤ Bypass table
When printing documents and using the manual paper feed setting, set paper onto on this table.
- ⑥ Bypass guide
- ⑦ Front cover
Open to set paper roll or in case of a paper jam.
- ⑧ Paper tray
Printed sheets will be stored here.
- ⑨ Paper tray support plate
Set in accordance with paper size.
- ⑩ Main switch
Turn this switch ON (|) in order to use the printer. Conversely, make sure this switch is OFF (⏻) before connecting network cables.
- ⑪ Total counter
This indicates the paper output length.
- ⑫ Key counter insert slot
When a key counter (option) is installed, insert the key counter here.

IMPORTANT

- Once you turn the main switch ON (|) wait for at least 20 seconds or so before attempting to turn it OFF (⏻) again. Failure to doing so may damage the printer.
- Make sure that you wait at least for 5 seconds after turned the main switch OFF (⏻) to remove the power plug from the outlet.

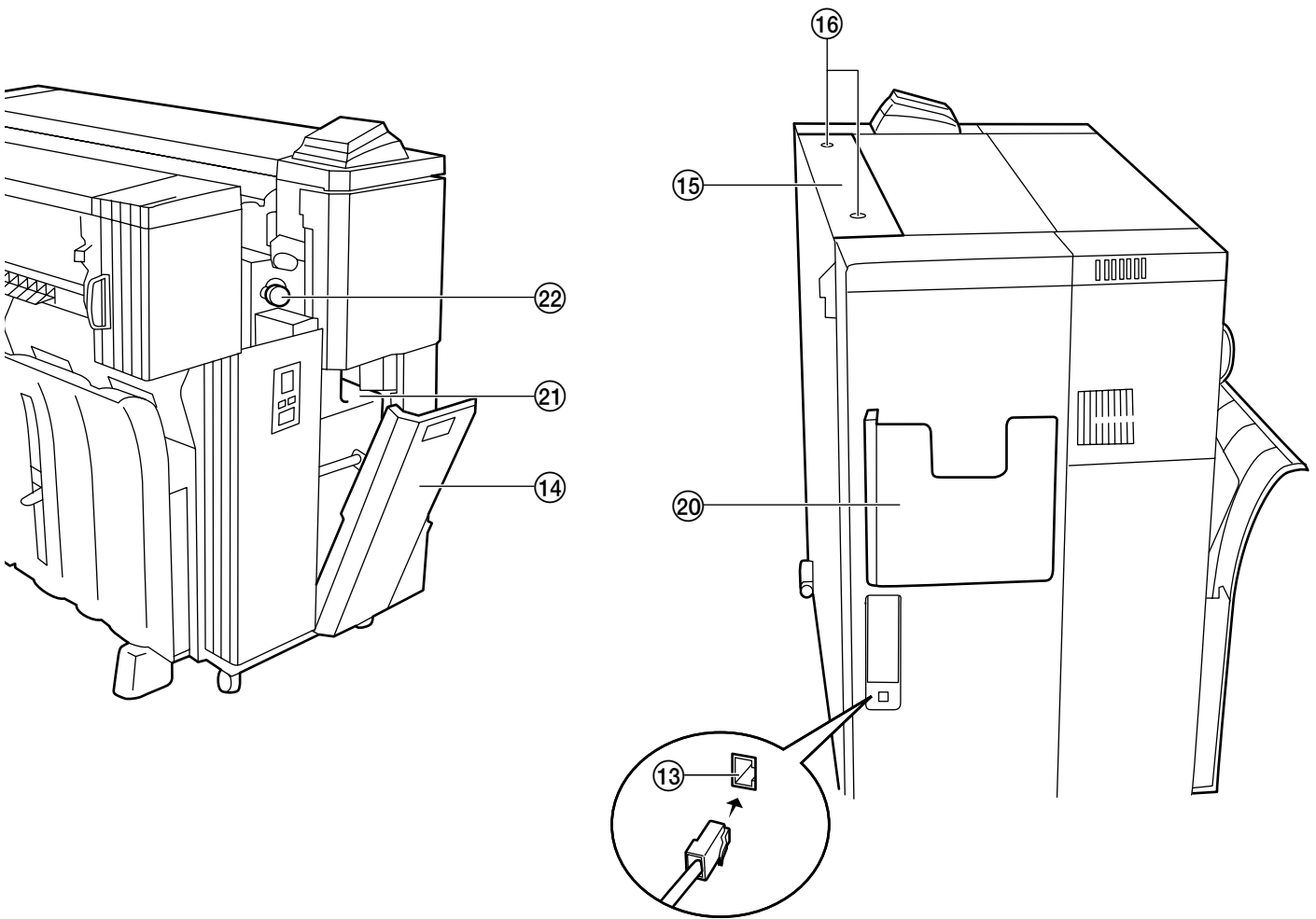

- ⑬ Network interface connector
Use to connect the printer to the LAN (Local Area Network) with a 10BASE-T or 100BASE-TX cable.
- ⑭ Right cover
Open to replace the waste toner tank.
- ⑮ Toner replenishing slot
Open to add toner.
- ⑯ Toner replenishing slot screw
Turn to open the toner replenishing slot.
- ⑰ Roll unit (paper source 1: option)
- ⑱ Roll unit (paper source 2)
- ⑲ Roll unit (paper source 3)
- ⑳ Operation Guide box
Keep the Operation Guide here.

- ㉑ Waste toner tank
- ㉒ Paper transport knob
Operate this knob in case of a paper jam.
- ㉓ Dew prevention heater switches
Switches for paper sources 1, 2, and 3.
- ㉔ Main heater switch
If this switch is turned off, the dew prevention heaters will be turned off even if the dew prevention heater switches inside the front cover are on.
- ㉕ Flanges
Set these on both sides of the paper roll.
- ㉖ Release levers
- ㉗ Flange guides

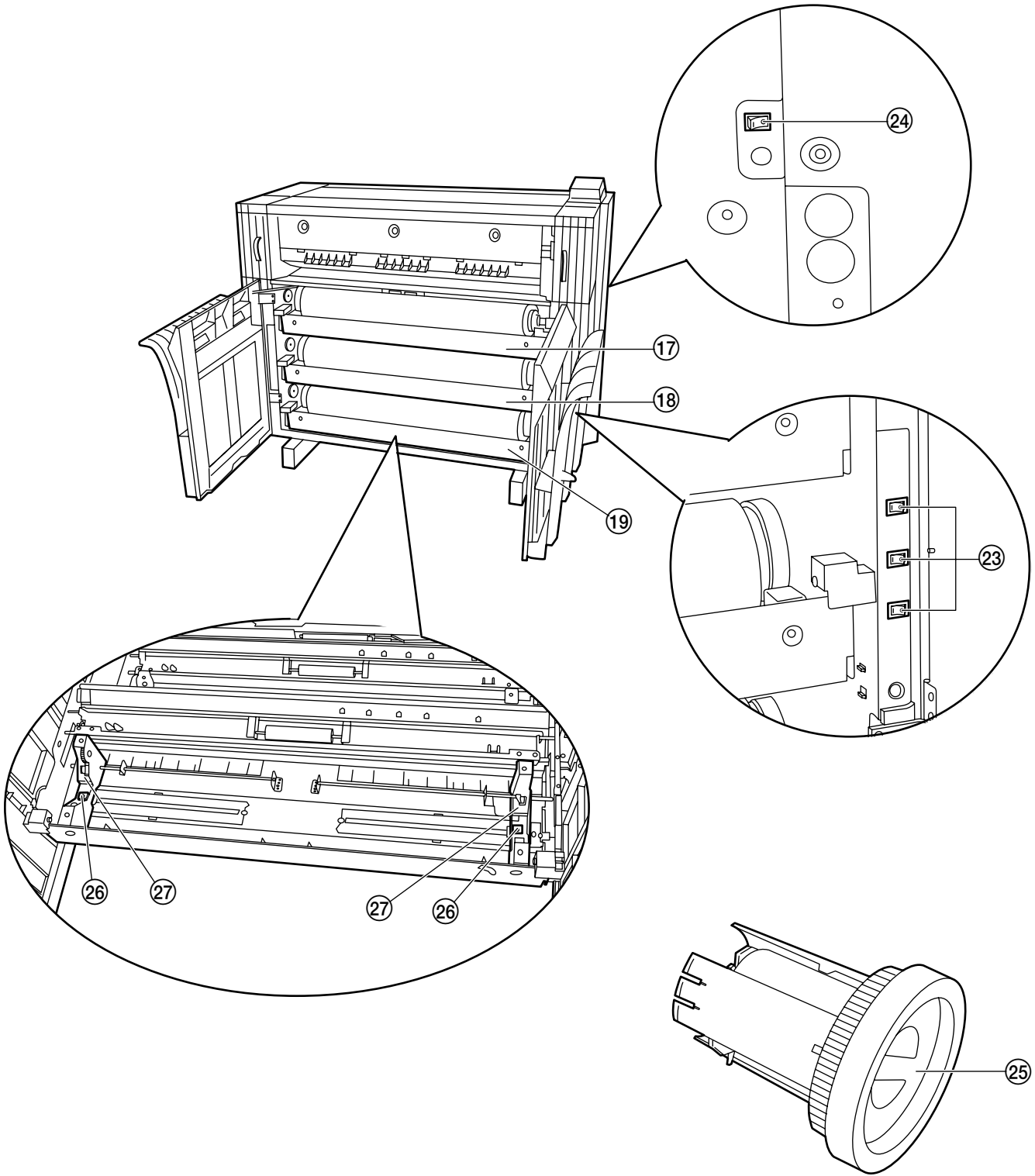

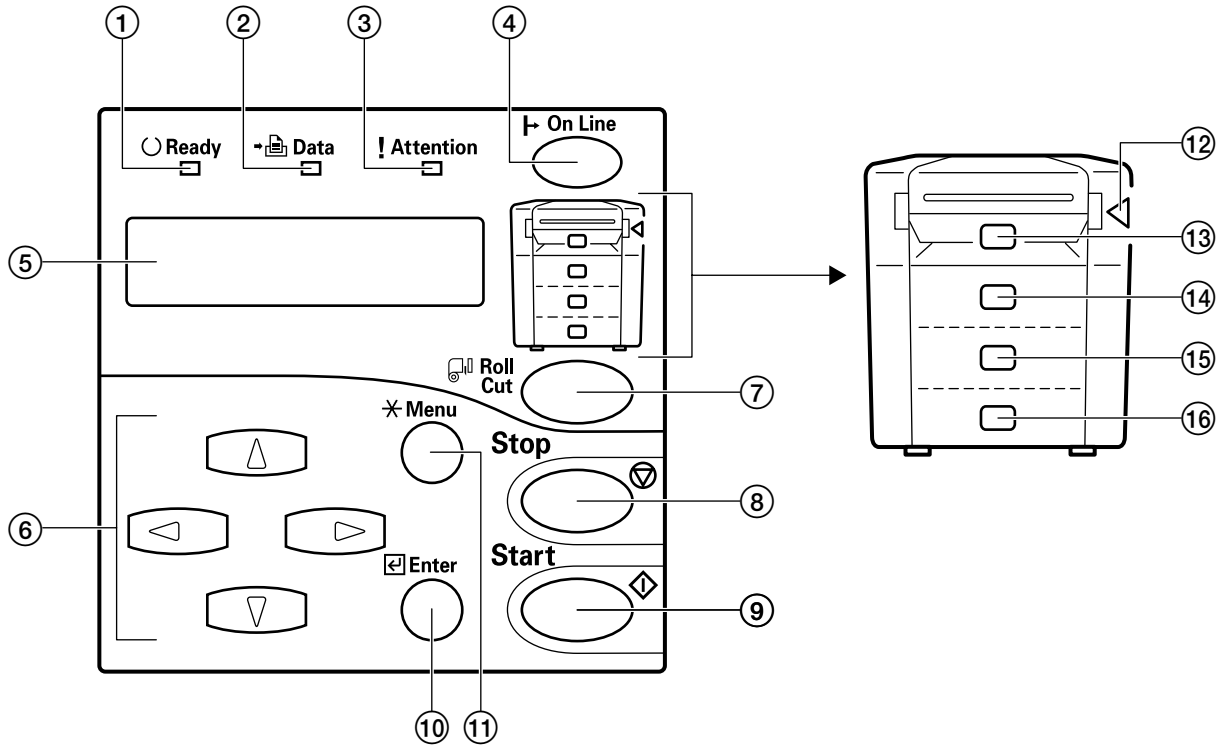

(2) Operation Panel

- ① Ready indicator
This indicator is lit when the printer is on-line and goes out when it is off-line. In addition, the indicator flashes while the internal server computer is starting up.
- ② Data indicator
This indicator flashes during printing.
- ③ Attention indicator
This indicator is lit when an error has occurred.
- ④ On Line key
Press this key when you want to switch the printer on- and off-line.
- ⑤ Message display
Machine status and errors are indicated on the message display.
- ⑥ ▲▼◀▶ Cursor keys
Use these cursor keys in order to select the various setting modes. In addition, the ▼ or ▲ key may be used to select a paper tray.
- ⑦ Roll Cut key
Press this key when a new paper roll is set. Also press to force a roll cut during output and to cancel printing.
- ⑧ Stop key
This key is used to cancel printing as well as in the configuration of some settings to clear entered values.
- ⑨ Start key
Press this key to print to the currently set paper roll when the print data's page size and/or media type do not match those of the current roll.
- ⑩ Enter key
Press this key when you want to register a setting. The Enter key is also used to return to the printer to standard mode from energy saver or sleep mode (Page 2-6).
- ⑪ */Menu key
Press this key to configure the printer's settings and output test prints. (When the */Menu key has been pressed and one of the printer setting screens is being displayed, the Ready indicator will go out and the printer will be off-line.)
- ⑫ Internal paper jam indicator
This indicator is lit when a paper jam has occurred inside the printer.
- ⑬ Manual feed indicator
This indicator is lit when the manual feed has been selected and when a paper jam has occurred in the manual feed mechanism.
- ⑭ Paper tray 1 indicator
This indicator is lit when the optional roll unit has been installed and paper tray 1 has been selected, as well as when a paper jam has occurred in paper tray 1.
- ⑮ Paper tray 2 indicator
This indicator is lit when paper tray 2 has been selected as well as when a paper jam has occurred in paper tray 2.
- ⑯ Paper tray 3 indicator
This indicator is lit when paper tray 3 has been selected as well as when a paper jam has occurred in paper tray 3.

2. Included Software

The following software can be found on the CD-ROM that is included with the printer.

NOTE

Refer to the Functions Edition (On-Line Manual) for the procedures for installing these printer drivers and utilities.

• Printer drivers

Printer drivers are included so that you can use the printer. The printer drivers are compatible for use with the following operating systems: Windows 95/98/Me, Windows NT 4.0, and Windows 2000.

• Printer drivers (for AutoCAD)

A printer driver compatible for use with AutoCAD2000i/2000/Release 14 is included.

• Macintosh PPD file

A PPD (PostScript Printer Description) file is included so that you can use the printer with a Macintosh computer.

• Print Utility

A Print Utility is included so that you can select a file to be printed without the need to open the corresponding application. (Up to 30 files can be selected at one time.)

The Print Utility is compatible for use with the following file formats: HP-GL, HP-GL2, HP-RTL, Calcomp906/PCI, Calcomp907/PCI, CALS_G4 (TIFF 6.0), DXF (AutoCAD standard, some settings restricted), TIFF, JPEG, BMP, DGN (optional) and CGM (optional)

The Print Utility is compatible for use with the following operating systems: Windows 95/98/Me, Windows NT 4.0, and Windows 2000

• KM-NET VIEWER

The KM-NET VIEWER is included so that you can manage a printer over the network from your computer.

• Functions Edition (On-Line Manual)

The Functions Edition (On-Line Manual) is prepared as a PDF (Portable Document Format) file. Read the Functions Edition together with this Operation Guide. Adobe Acrobat Reader 4.0 must be installed in your computer in order to read the Functions Edition (On-Line Manual).

• Adobe Acrobat Reader

Acrobat Reader 4.0 is included so that you can read and print the Functions Edition (On-Line Manual).

3. Required Items

The following items are not included with the printer and must be purchased separately.

• Network cable

(Twisted-pair 10BASE-T or 100BASE-TX [category 5])

NOTE

Be sure to use a "shielded type" network cable.

• Network hub

4. Energy Saver Function

The automatic energy saver function automatically sets the printer to a low energy consumption mode when the printer has not been used for a specific period of time. When in energy saver mode the message "Pre heating" ["Now preheating"] will be displayed. Upon detection of a print signal from the computer, the printer automatically returns to its standard mode and starts printing. Pressing the Enter key will also cause the printer to return to standard mode. The time until the energy saver function activates (auto energy saver time) is set to a factory default of 15 min. This value can be set in the machine setting "6. Timer set" from 5 to 45 min., in 5 min. increments (Page 5-7).

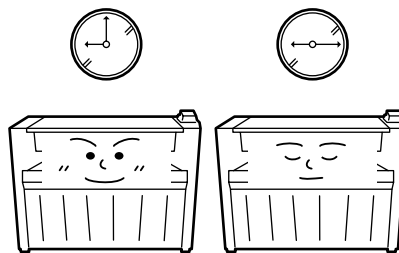

5. Auto Shutoff Function

The auto shutoff function consists of shutoff mode and sleep mode. The factory default is set to sleep mode.

- **Shutoff mode:** Power is automatically turned OFF (⏻) when the printer has not been used for a specific period of time. To return to normal operation from shut-off mode, turn ON (⏻) the main switch.
- **Sleep mode:** The printer enters a sleep state when it has not been used for a specific period of time. The message "Sleeping" will be displayed when the printer is in sleep mode. Upon detection of a print signal from the computer, the printer automatically wakes up and starts printing. Pressing the Enter key will also cause the printer to wake up.

The auto shut-off function can be configured in the machine setting "5. Auto shutoff" (Page 5-7). The time until the auto shutoff feature activates (auto shutoff time) is set to a factory default of 90 min. This value can be set in the machine setting "6. Timer set" from 15 to 120 min., in 5 min. increments (Page 5-7).

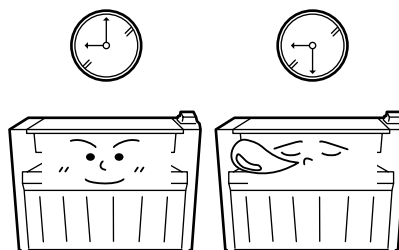

CHAPTER 3 GETTING READY FOR PRINTING

1. Setup

(1) System Configuration

● Printing from Windows

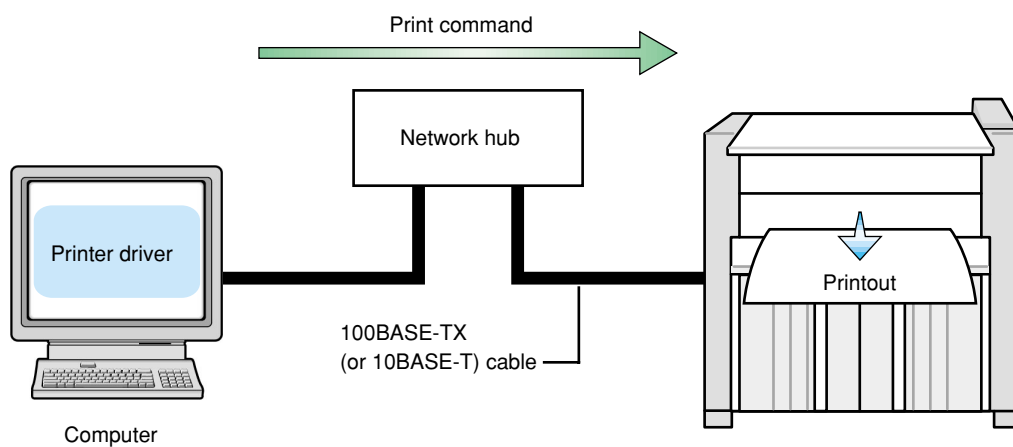

● Printing from Macintosh

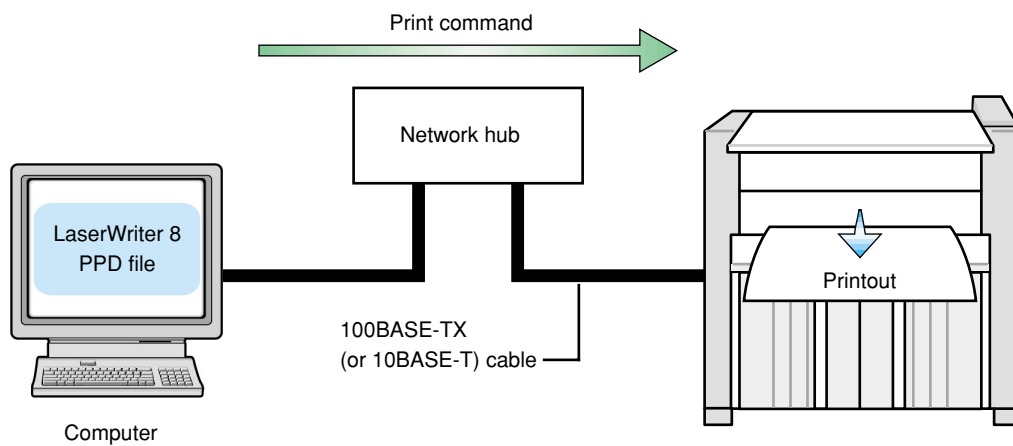

(2) Procedures

● Connecting the Printer to Your Network

Perform this procedure in order to connect the printer to the network hub.

- 1 Turn the main switch on the printer OFF (⏻).

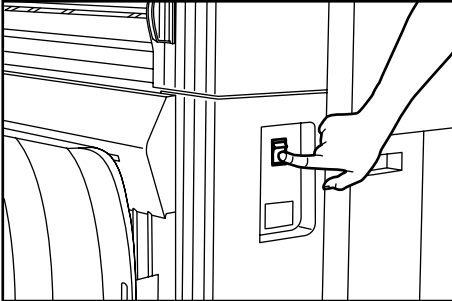

CAUTION

Make sure the main switch is OFF (⏻) before connecting the network cable.

- 2 Plug the network cable into the Network Interface Connector which is located on the left side of the printer.

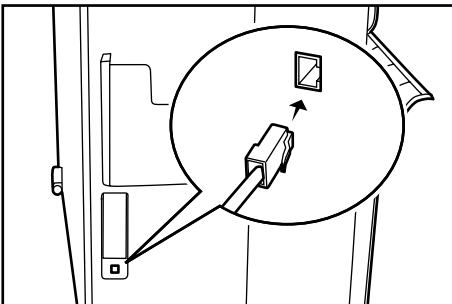

- 3 Plug the other end of the network cable into the network hub.

- 4 Turn the main switch on the printer back ON (⏻).

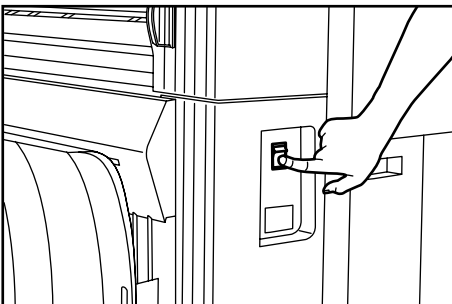

● Network Settings [Configuring the IP Address, etc.]

Perform this procedure in order to register the required network settings.

NOTE

- The IP address to be used for the printer will differ depending upon your network. Confirm the address that you need to use in advance with your network manager.
- If you will use a DHCP server to designate the IP address, there is no need to perform the following procedure because the factory default for the printer is set for DHCP server configuration.
- The "*" in a list of setting options indicates the current setting.

- 1 Press the */Menu key.

- 2 Press the ▼ or ▲ key to select "3. Set/manager".

Inch specifications

Menu:
3.Set/manager

Metric specifications

Menu:
3.Set/manager

- 3 Press the Enter key.

- 4 Use the ▲▼◀▶ cursor keys to input the pin code (the default setting is ↑↓↔).

Inch specifications

Enter pin code.

_ _ _ _

Metric specifications

Enter pin code.

_ _ _ _

NOTE

The pin code may be changed (see "13. Mgr. code change" on page 5-10).

5 Press the ▼ or ▲ key to select “2. Set printer”.

Inch specifications

```
Set/manager:
2.Set printer
```

Metric specifications

```
Set/manager:
2.Set printer
```

6 Press the Enter key.

7 Press the ▼ or ▲ key to select “3. DHCP server”.

Inch specifications

```
Set printer:
3.DHCP server
```

Metric specifications

```
Set printer:
3.DHCP server
```

8 Press the Enter key.

9 The selected item will flash. Press the ▼ or ▲ key to select “OFF”.

Inch specifications

```
DHCP server:
=>OFF<=
```

Metric specifications

```
DHCP server:
=>OFF<=
```

10 Press the Enter key.

11 Press the ▼ or ▲ key to select “4. IP address”.

Inch specifications

```
Set printer:
4.IP address
```

Metric specifications

```
Set printer:
4.IP address
```

12 Press the Enter key.

13 Use the ▲▼◀▶ cursor keys to input the IP address.

Inch specifications

```
IP address:
=>0<= 0. 0. 0
```

Metric specifications

```
IP address:
=>0<= 0. 0. 0
```

In order to set the IP address to “192.168.0.1”, perform the following procedure.

1 Press the ▼ or ▲ key to display “192”.

Inch specifications

```
IP address:
=>192<= 0. 0. 0
```

Metric specifications

```
IP address:
=>192<= 0. 0. 0
```

2 Press the ▶ key. The next value will flash.

Inch specifications

```
IP address:
192.=>0<= 0. 0
```

Metric specifications

```
IP address:
192.=>0<= 0. 0
```

3 Press the ▼ or ▲ key to display “168”.

Inch specifications

```
IP address:
192.=>168<= 0. 0
```

Metric specifications

```
IP address:
192.=>168<= 0. 0
```

4 Press the ▶ key. The next value will flash.

Inch specifications

```
IP address:
192.168.=>0<= 0
```

Metric specifications

```
IP address:
192.168.=>0<= 0
```

5 Press the ► key. The next value will flash.

Inch specifications

IP address:
192.168. 0. 0

Metric specifications

IP address:
192.168. 0. 0

6 Press the ▼ or ▲ key to display “1”.

Inch specifications

IP address:
192.168. 0. 1

Metric specifications

IP address:
192.168. 0. 1

NOTE

Press the Stop key if you want to enter the address once again from the beginning. The displayed IP address will return to its previous value.

14 Press the Enter key.

15 Use the same procedure in order to set the “5. Subnet mask”, “6. Gateway”, and “7. WINS server” information.

16 Once you have completed all of the required settings, press the ▼ or ▲ key to select “End” and then press the Enter key.

Inch specifications

Set printer:
End

Metric specifications

Set printer:
End

17 Press the ▼ or ▲ key to select “End” [“back”] and press the Enter key.

Inch specifications

Set/manager:
End

Metric specifications

Set/manager:
back

18 Press the ▼ or ▲ key to select “End” and press the Enter key.

Inch specifications

Menu:
End

Metric specifications

Menu:
End

● Name Settings [Changing the Computer (Device) and Host Names]

Perform this procedure in order to register the required name settings [the computer (device) name and host name]. The Web Manager interface is utilized to make these settings.

NOTE

- Since there is a danger of communications trouble occurring if another computer on your network is using the same computer name, be sure to consult with your network manager in advance when selecting the name that you want to use for the printer.
- Be sure to use the same name for both the printer’s computer (device) name and host name.
- Use the Internet Explorer browser application on another client computer in order to access the Web Manager interface.
- In order to use the Web Manager interface it is necessary to register the correct IP address in the printer in advance. Refer to “● Network Settings [Configuring the IP Address, etc.]” on page 3-2.
- While this section only explains how to set the computer (device) name and host name using the Web Manager interface, Web manager is convenient for a number of uses. Refer to the Functions Edition (On-Line Manual) or the Help icon in the Web Manager interface for more detailed information.

1 Start up a client computer that can access the printer over the network.

2 Run Internet Explorer on that computer.

3 Enter the following URL:
http://<IP address of the printer>/

NOTE

The current IP address can be verified in the “● Network Settings [Configuring the IP Address, etc.]” procedure on page 3-2.

4 The login screen will appear. Enter “Administrator” for the user name and click on [OK].

5 Once you have logged on successfully, the Web Manager wizard will appear. Click on [Kyocera Mita Wide format Web Manager] at the bottom of the wizard screen.

- Click on [System] in the icons on the left side of the Web Manager interface.



- Click on the [Server Setting] tab in the [System] screen to view the contents of that tab.

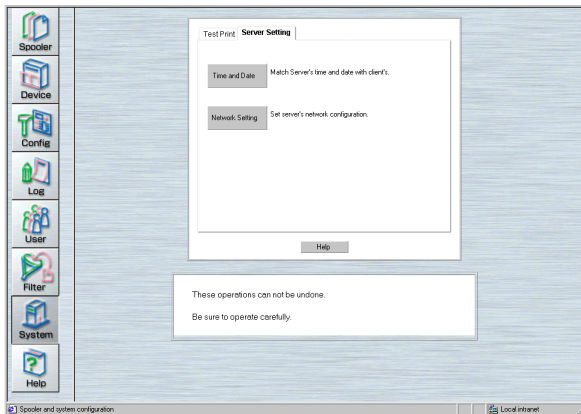

- Click on the [Network Setting] button to display the [Network Configuration] screen.

- Enter the appropriate information in the [Computer Name] and [Host Name] fields.

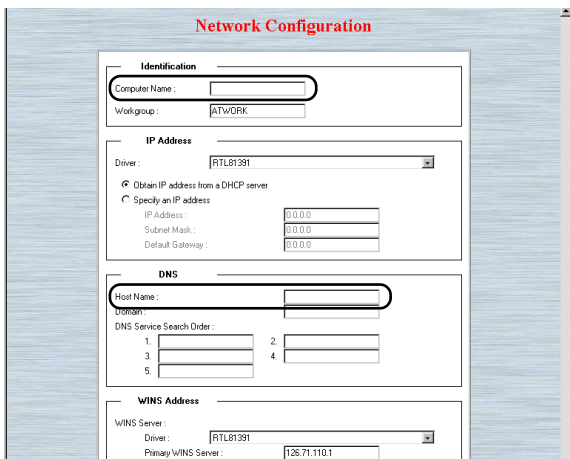

NOTE

Be sure to enter the same information in both the [Computer Name] and [Host Name] fields.

- Click on the [Enter] button to complete configuration of the computer (device) name and host name.

2. Paper

(1) Paper Type

Note the following restrictions on paper that can be used in this machine.

● Compatible paper

1. Paper source 1 (option), paper source 2, and paper source 3
 - Paper roll width: 17" to 36" [210 to 920 mm]
 - Paper roll outer diameter: 6 3/4" [180 mm] or less
 - Paper roll inner diameter: 3" [76 mm (75.2 to 77.2 mm)]
 - Acceptable paper roll types
 - Plain paper (64 to 80 g/m²)
 - Vellum
 - Film
2. Bypass
 - Paper sizes (standard paper): 8 1/2" x 11" to 36" x 48" [A4 portrait to A0]
 - Paper width: 8 1/2" to 36" [210 to 920 mm]
 - Paper length: 11" to 48" [297 to 1189 mm]
 - Acceptable paper materials
 - Plain paper (64 to 80 g/m²)
 - Vellum
 - Film

● Unacceptable paper

- Paper other than the paper described in "● Compatible paper"
- Paper with staples, etc.
- If paper is wrinkled, folded or broken, unroll the paper until the problem disappears and cut the paper before using it.

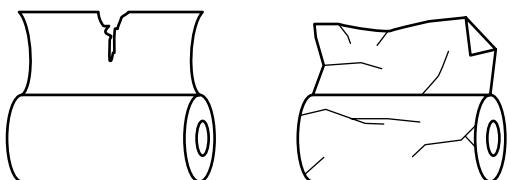

● Automatic paper width detection

If the paper roll that has been set is of a standard size, the paper width will be automatically detected. The following sizes can be detected.

Inch specifications	Metric specifications
<Architecture>	<A sizes>
36"	A0: 841mm
24"	A1: 594mm
18"	A2: 420mm
12"	A3: 297mm
9"	A4: 210mm
<Engineering>	<B sizes>
34"	B1: 728mm
22"	B2: 515mm
17"	B3: 364mm
11"	B4: 257mm
8 1/2"	

NOTE

- Automatic detection will not function for the bypass.
- Paper width of non-standard sizes can be registered. See "1. Paper width" in the default setting. (Page 5-6)
- For switching between standard sizes (architecture/engineering [A sizes/ B sizes]), see "10. Standard size" in the default settings. (Page 5-9)

● Storage of paper

If the machine is not used for an extended period time, remove the paper roll and return it to its original packaging and reseal it.

IMPORTANT

- Vellum
 - Since vellum is very susceptible to its environment, when it is not used, put it in a plastic bag and seal it.
 - When using vellum at a high humidity or at a low temperature, vellum will become fragile, resulting in wrinkles prints or missing images. If images are not properly printed, perform the following procedure.
 - * When using cut vellum:
 - Change the orientation of the paper (portrait or landscape).
 - * When using a vellum roll:
 - Unroll 1 length of paper and cut the paper before using it.
 - When using roll paper whose surface is contaminated with adhesive, remove the adhesive or unroll the paper until the adhesive is no longer visible and cut off the unusable length.

(2) How to Set a Paper Roll

Use the same procedure when replacing a paper roll.

IMPORTANT

When replacing a paper roll, turn the flanges on both sides to rewind the paper.

- 1** Open the front cover until it locks.
- 2** Grasp the roll unit handles (A) to release the lock and pull out the roll unit until it stops.

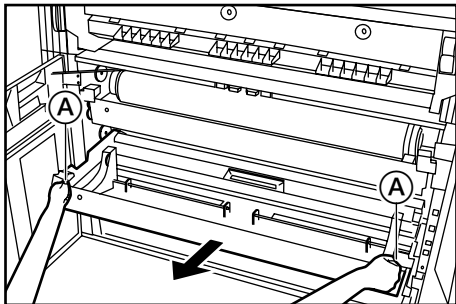

- 3** Lift up the release levers (1) and adjust the flange guides (2) on both sides to the paper size.

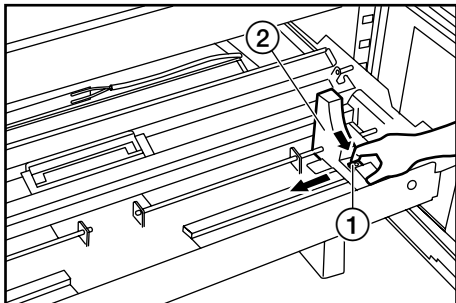

- 4** Insert an included flange into the core of the new roll.

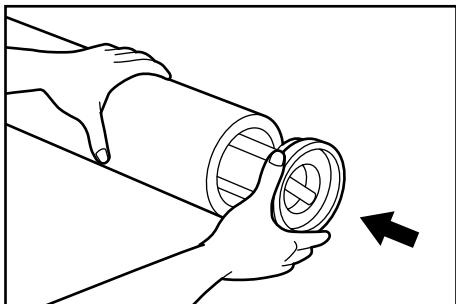

- 5** Grasp the flange and turn its lever in the direction indicated by the arrow to align the inside and outside Δ marks on the flange. The flange will be secured to the paper roll.

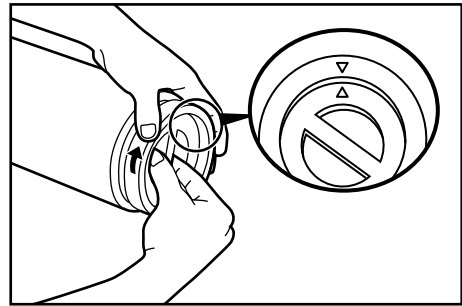

IMPORTANT

If the lever of the flange is not easily turned, attach the included flange handle (B) and turn the flange handle in the direction indicated by the arrow to align the inside and outside Δ marks on the flange.

* Also if the lever of the flange is not easily turned when the flange is removed, use the flange handle.

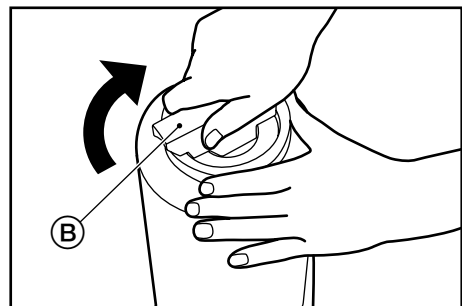

- 6** Secure the other flange to the paper roll similarly.
- 7** Set the paper roll in the roll unit by aligning it with the flange guides (2). After setting the paper roll, check that the flange tray has not moved.

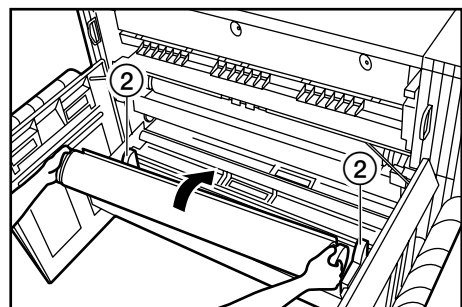

- 8** Grasp both paper roll insertion latches (3) and open the paper roll insertion cover (4).

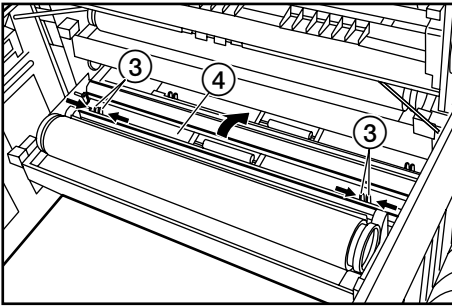

- 9** Insert the leading edge of the paper under the paper roll insertion guide and advance the edge past the guide approximately 1/2" [10 mm] as shown in the illustration.

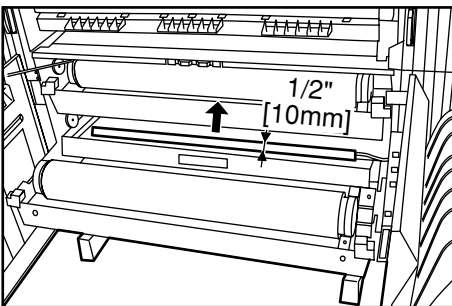

IMPORTANT

If the paper roll that has been set is slackened, grasp the flange and wind the paper roll to remove the slack. If not, the paper may be fed obliquely.

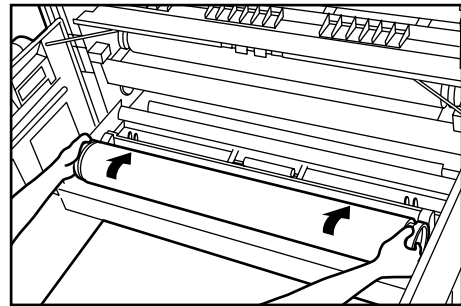

- 11** Insert the roll unit securely into the main body of the machine.

- 12** Close the front cover.

- 13** To align the leading edge of the paper roll, use the ▼ or ▲ key to select a paper tray and press the Roll Cut key. The leading edge of the paper roll will be ejected from the paper eject slot.

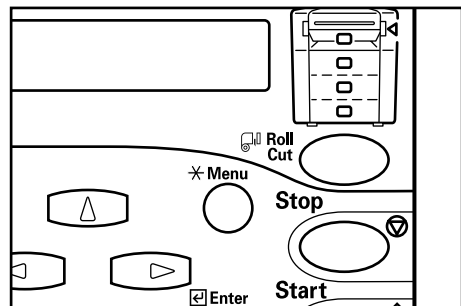

NOTE

If the leading edge of the paper roll is folded or broken, cut a clean edge using a cutter.

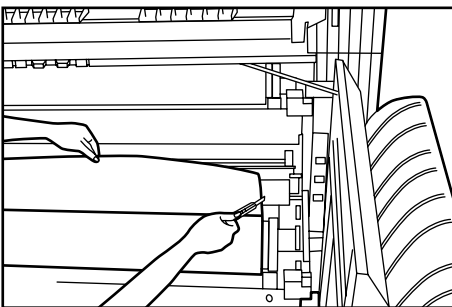

NOTE

- Paper is normally cut in lengths of 11" [279 mm]. If the temperature in the machine is lower than 15 °C, however, vellum will be cut in lengths of 31" [800 mm].
- When a paper roll has been replaced during printing, press the On Line key to place the printer offline and then press the Roll Cut key. To continue printing press the On Line key once more to place the printer online.

- 10** Grasp the paper roll insertion latches and close the paper roll insertion cover securely.

(3) Dew prevention heater

If the humidity is high (more than 70 %RH) or drastic temperature change occurs, turn on (I) the dew prevention heater switch when using the machine. Even if the main switch is off (⏻), the dew prevention heater switch can be on (I).

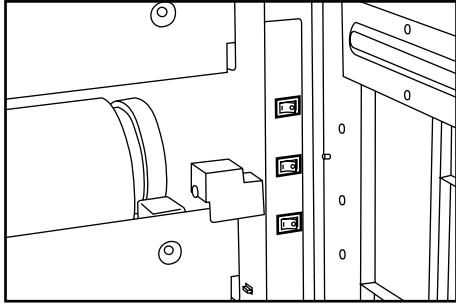

IMPORTANT

When using vellum or film, be sure to turn off (O) the dew prevention heater switch. If not, paper may be wrinkled or curled.

(4) How to Use the Paper Tray Support Plate

Set the paper tray support plate based on the paper to be used for printing.

- 1 Incline the paper tray support plate and slide it to the size indication on the size label of the paper tray.

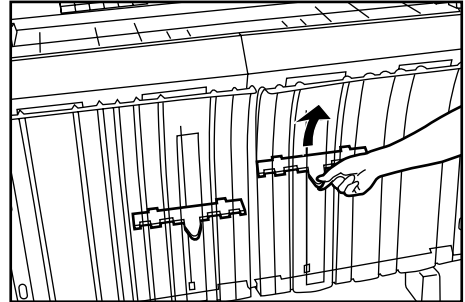

- 2 After setting the paper tray support plate to the desired size, return it to a horizontal state.

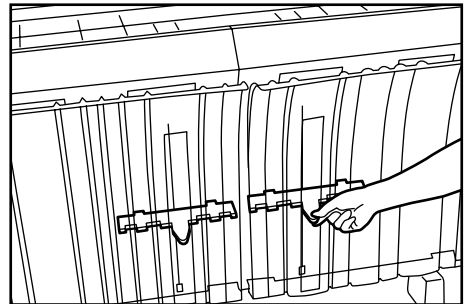

- 3 Follow the same procedure to set the other paper tray support plate to the same height. Depending on the paper to be used and the environment, the support plate may not be contained at the position of the size label. In this case, adjust the position of the paper tray support plate upward or downward.

CHAPTER 4 PRINTER OPERATION

1. Basic printing

Perform this procedure in order to send commands to the printer from your computer.

- 1 Turn the main switch on the printer ON (|).
The printer will begin to warm up and "Ready to print." will be displayed once warm-up is complete.

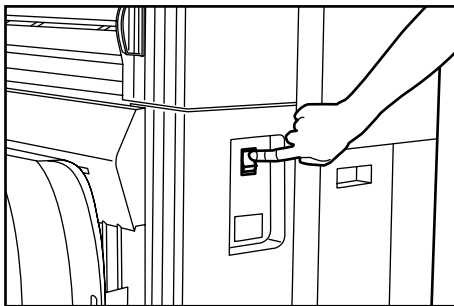

- 2 Make sure that the Ready indicator is lit.

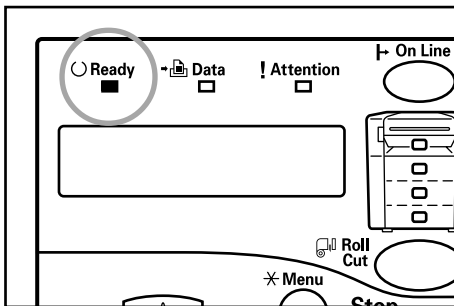

- 3 Perform the appropriate printing procedure on your computer.

NOTE

Refer to the Functions Edition (On-Line Manual) for more detailed information on printing from your computer.

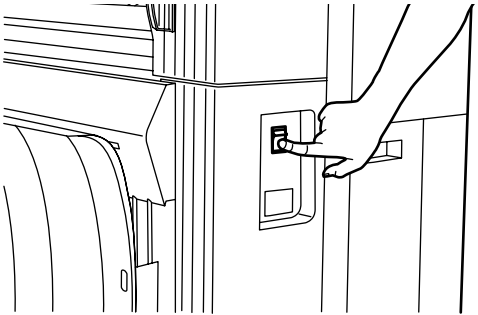
A line drawing showing a hand turning a switch on the printer to the 'OFF' position. The switch is a small rectangular button with a vertical line through it.

! CAUTION

If the printer will not be used for a short period of time (overnight, etc.), turn the main switch OFF (|). If it will not be used for an extended period of time (vacations, etc.), remove the power plug from the outlet for safety purposes during the time the printer is not in use.

2. Printing with manually fed media

When printing through the bypass slot, perform the following procedure.

NOTE

- Only one sheet of paper can be set onto the bypass table at a time.
- When using curled paper, smooth the paper. If the curling persists, place the paper with the curled surface up.

- 3** Perform the appropriate printing procedure on your computer.

NOTE

Refer to the Functions Edition (On-Line Manual) for more detailed information on printing from your computer.

- 1** Adjust the bypass guides to the paper size indications on both sides of the bypass table.

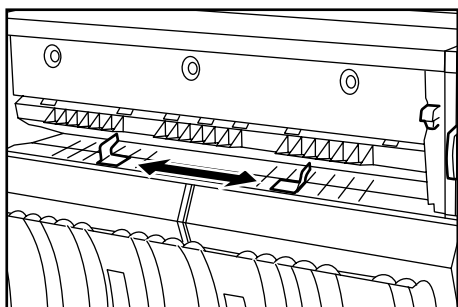

- 4** When the message “Set paper. bypass” appears, refer to Step 2 and set the next sheet onto the bypass table. Printing will start. Repeat this procedure to set sheets one at a time onto the bypass table until the required number of sheets has been loaded and printed.

- 2** Set the paper face down all the way into the feed slot aligned with the paper size indication.

When placing paper in the bypass table, set the paper quickly all the way into the feed slot. Once the paper is fed, release the paper. If the paper is not set properly, a paper jam may be detected.

If the paper is set obliquely, pull the paper out and then insert it again.

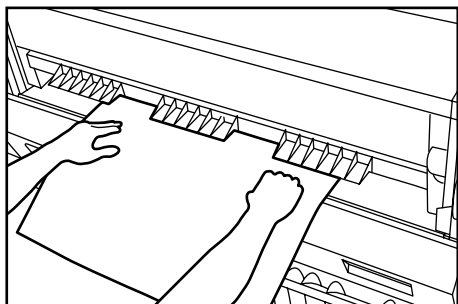

3. Making a Test Print

Perform this procedure to send a test print command from the printer's operation panel.

NOTE

In order to make a test print, you must place a sheet of 8 1/2" x 11" [A4] paper onto the bypass table in portrait orientation.

1 Refer to "2. Printing with manually fed media" (Page 4-2) and place an 8 1/2" x 11" [A4] sheet of paper onto the bypass table in portrait orientation.

2 Press the */ Menu key.

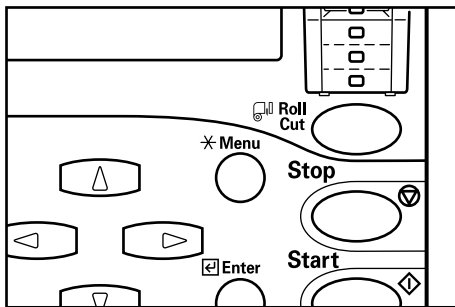

3 Press the ▼ or ▲ key to select "2. Set/user".

Inch specifications

Menu:
2.Set/user.

Metric specifications

Menu:
2.Set/user

4 Press the Enter key.

5 Press the ▼ or ▲ key to select "2. Set printer".

Inch specifications

Set/user:
2.Set printer

Metric specifications

Set/user:
2.Set printer

6 Press the Enter key.

7 Press the ▼ or ▲ key to select "2. Test print".

Inch specifications

Set printer:
2.Test print

Metric specifications

Set printer:
2.Test print

8 Press the Enter key.
A test print will be automatically output.

NOTE

Making a test print from the Web Manager interface

It is possible to use an Internet Web browser on a client computer to access the Web Manager interface and print out a list of setting information.

For a more detailed explanation, refer to the Functions Edition (On-Line Manual).

4. Canceling Printing

If "Processing data." or "Printing" ["Now printing."] is shown in the message display, press the Stop key. The current print job will be cancelled.

Inch specifications

Processing data.

Printing

Metric specifications

Processing data.

Now printing.

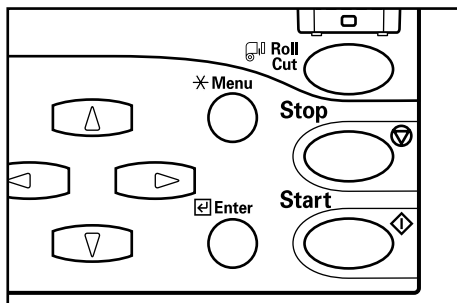

Press the Roll Cut key to cut the sheet being printed and immediately stop printing.

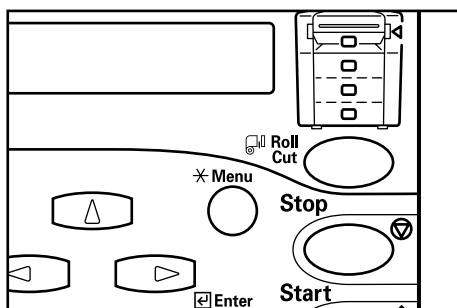

The procedure to cancel all print jobs must be performed from the computer. For more information, see the Functions Edition (On-Line Manual).

5. Resetting the printer

If the printer operation stops or becomes unstable, reset the printer and reboot the internal server computer.

- 1 Press the */Menu key.

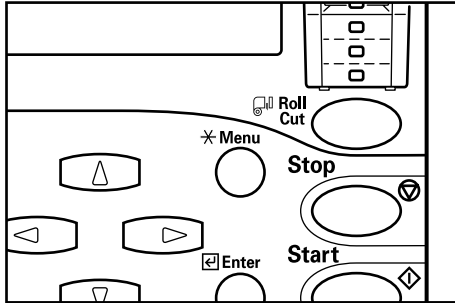

- 2 Press the ▼ or ▲ key to select "2. Set/user".

Inch specifications

Menu:
2.Set/user.

Metric specifications

Menu:
2.Set/user

- 3 Press the Enter key.

- 4 Press the ▼ or ▲ key to select "2. Set printer".

Inch specifications

Set/user:
2.Set printer

Metric specifications

Set/user:
2.Set printer

- 5 Press the Enter key.

- 6 Press the ▼ or ▲ key to select "1.Reset".

Inch specifications

Set printer:
1.Reset

Metric specifications

Set printer:
1.Reset

- 7 Press the Enter key.

- 8 The selected option will flash. Press the ▼ or ▲ key to select "Yes".

Inch specifications

Reset?
=Yes<

Metric specifications

Reset?
=Yes<

- 9 Press the Enter key.
All scheduled print jobs will be canceled.

CHAPTER 5 MANAGEMENT AND SETTING

The */Menu key on the operation panel can be used to configure settings such as the paper width and media type for each of the paper trays, the printer's IP address, etc.

Based on their content, settings are divided into "Machine settings" that configure the printer's operation and "Printer settings" that configure the printer's IP address and related network information. In addition they are divided according access privilege: there is a subset that offers limited control to any "User", while full access to all settings is reserved for the "Manager". Input of the pin code is required for the manager to configure settings.

For a description of each setting, see "(1) List of Machine Settings" and "(2) List of Printer Settings" (Page 5-11).

1. Machine Default

(1) List of Machine Settings

● Settings common to user/manager

Setting	Description	Selectable values	Default	Page
1. Paper width	If this item is set to "Input size", a non-standard paper width can be set. Use the ▼ or ▲ key to enter the paper width for each paper source.	For each paper source: Auto size/ Input size (17"~36" [210mm~920mm])	Auto size	5-6
2. Media Type [Pre-set Temp.]	If this item is set to "ON", a media type can be registered for each paper source. Fixing temperature, print size, and fix/unfix of roll end will be set based on the registered paper material.	ON/OFF	OFF	5-6
3. Paper type [Paper material]	If "2. Media Type [Pre-set Temp.]" is set to "ON", a media type can be set for each paper source including the bypass table. If "Custom" is selected, fixing temperature, print size, etc. will be set based on "9. Custom paper".	For each paper source: Plain/Vellum/ Film/Custom	Plain	5-6
4. Roll end	This item sets whether or not paper roll end is fixed to the core of the roll. If "Fixed" is selected, paper will be automatically cut when paper runs out.	For each paper material: Unfix [Unfixed]/ Fixed	Unfix [Unfixed] (Film: Fixed)	5-7

CHAPTER 5 MANAGEMENT AND SETTING

● Settings accessible by manager

Setting	Description	Selectable values	Default	Page
5. Auto shutoff	This setting allows the selection of two modes of operation that take effect when the printer has not been used for a specific period of time: shutoff mode, which automatically turns off the printer (Page 2-6), or sleep mode, which automatically places the printer in a sleep state (Page 2-6). You may also choose "OFF" if you will not be using the auto shutoff feature.	Shutoff mode/ Sleep mode/OFF	Shutoff mode	5-7
6. Timer set	This item sets the time that elapses before auto energy saver (Page 2-6) or auto shutoff (Page 2-6) is activated. If the printer is used frequently, it is recommended that the time for auto shutoff be longer. If the printer is not used for long periods of time, it is recommended that the time be shorter.	Auto energy saver time: 5 to 45 minutes in 5 minute increments Auto shutoff time: 15 to 120 minutes in 5 minute increments	15 minutes 90 minutes	5-7
7. Size adjustment	Print size can be adjusted for each media type.	For each paper material: X (width) -3.0 % to +3.0 % Y (length) -3.0 % to +3.0 %	X: ±0.0 % Y: ±0.0 %	5-8
8. Fusing temp.	The fixing temperature can be changed for each media type. Set a higher temperature for thick paper and a lower temperature for thin paper. * For custom paper, a fixing temperature for the paper material selected in "9. Custom paper" can be selected.	Plain: 145 °C, 155 °C, 165 °C Vellum: 165 °C, 175 °C, 185 °C Film: 150 °C, 160 °C, 170 °C Custom: The media type configured in "9. Custom paper" and its respective fixing temperatures.	155 °C 175 °C 150 °C Vellum 165 °C	5-9
9. Custom paper	This setting allows the selection of a media type for custom paper. The selection made here is linked to the "Size adjustment" and "Fusing temp." custom settings. * Check the "7. Size adjustment" and "8. Fusing temp." custom setting values after changing the media type selected here.	Plain/Vellum/Film	Vellum 165 °C X: ±0.0 % Y: ±0.0 %	5-9

Setting	Description	Selectable values	Default	Page
10. Standard size	Select either "Architecture" or "Engineering" ["A sizes" or "B sizes"] for the paper size. This will change the media widths that are automatically detected by the printer.	Architecture/ Engineering [A sizes/B sizes]	Architecture [A sizes]	5-9
11. Auto roll over	If paper of the same size is set in multiple paper sources, when paper in a paper source runs out during printing, another paper source will be automatically selected and printing will continue. If "2. Media Type [Pre-set Temp.]" is set to "ON", however, auto roll over will not function between different media types of the same size.	ON/OFF	OFF	5-10
12. Buzzer	When the printer runs out of paper or experiences a paper jam during printing, this status can be conveyed by a buzzer in addition to the messages displayed on the operation panel. This feature is particularly convenient when the printer is not located in the immediate vicinity of the operator. The buzzer sounds at the following conditions: <ul style="list-style-type: none"> • When the printer runs out of paper during printing; • When the data page size and/or media type differ from those of the selected paper tray; • When there is a paper jam; • When the printer runs out of toner; • When the waste toner tank is full; • When the "Call service" message is displayed; • When another printer error has activated the Attention indicator on the operation panel. 	ON/OFF	ON	5-10
13. Mgr. code change	The password setting for manager can be changed. * Using the ▲▼◀▶ cursor keys, select a 4-symbol combination of the up/down/left/right arrows to set the pin code. * When changing the pin code, it is recommended that you make a note of the new code.	-----	↑ ↓ ← →	5-10

(2) Configuring Machine Setting

● Configuration by user

1 Press the */Menu key.

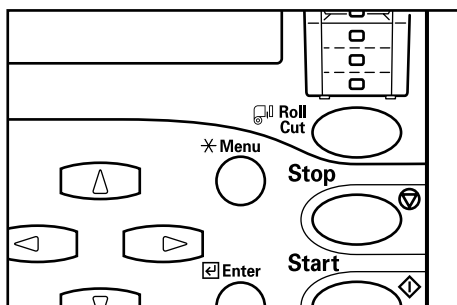

2 Press the ▼ or ▲ key to select "2. Set/user".

Inch specifications

Menu:
2.Set/user.

Metric specifications

Menu:
2.Set/user

3 Press the Enter key.

4 Press the ▼ or ▲ key to select "1. Set machine".

Inch specifications

Set/user:
1.Set machine

Metric specifications

Set/user:
1.Set machine

5 Press the Enter key.

6 Press the ▼ or ▲ key to select a setting and press the Enter key.

Inch specifications

Set Machine:
1.Paper width

Metric specifications

Set Machine:
1.Paper width

Configure each item, referring to the following pages:

1. Paper width...Page 5-6
2. Media Type [Pre-set Temp.]...Page 5-6
3. Paper type [Paper material]...Page 5-6
4. Roll end...Page 5-7

* The "*" in a list of setting options indicates the current setting.

7 To configure another item, return to step 6.
To complete configuration, press the ▼ or ▲ key to select "End" ["back"] and press the Enter key.

NOTE

- After each item has been configured, press the */Menu key to return to the "Ready to print." screen.
- If you make a mistake when configuring an item, press the */Menu key. The display will return to the "Ready to print." screen, leaving the setting unchanged.

8 Press the ▼ or ▲ key to select "End" and press the Enter key.

● Configuration by manager

1 Press the */Menu key.

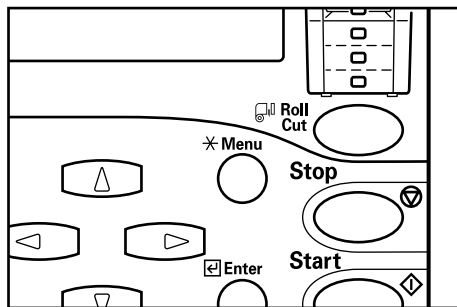

2 Press the ▼ or ▲ key to select “2. Set/manager”.

Inch specifications

Menu:
3.Set/manager

Metric specifications

Menu:
3.Set/manager

3 Press the Enter key.

4 Use the ▲▼◀▶ cursor keys to input the pin code (the default setting is ↑↓↔).

Inch specifications

Enter pin code.
_ _ _ _

Metric specifications

Enter pin code.
_ _ _ _

NOTE

The pin code may be changed (see “13. Mgr. code change” on page 5-10).

5 Press the ▼ or ▲ key to select “1. Set machine”.

Inch specifications

Set/manager:
1.Set machine

Metric specifications

Set/manager:
1.Set machine

6 Press the Enter key.

7 Press the ▼ or ▲ key to select a setting and press the Enter key.

Inch specifications

Set Machine:
1.Paper width

Metric specifications

Set Machine:
1.Paper width

Configure each item, referring to the following pages:

1. Paper width...Page 5-6
2. Media Type [Pre-set Temp.]...Page 5-6
3. Paper type [Paper material]...Page 5-6
4. Roll end...Page 5-7
5. Auto shutoff...Page 5-7
6. Timer set...Page 5-7
7. Size adjustment...Page 5-8
8. Fusing temp....Page 5-9
9. Custom paper...Page 5-9
10. Standard size...Page 5-9
11. Auto roll over...Page 5-10
12. Buzzer...Page 5-10
13. Mgr. code change...Page 5-10

* The “*” in a list of setting options indicates the current setting.

8 To configure another item, return to step 6. To complete configuration, press the ▼ or ▲ key to select “End” [“back”] and press the Enter key.

NOTE

- After each item has been configured, press the */Menu key to return to the “Ready to print.” screen.
- If you make a mistake when configuring an item, press the */Menu key. The display will return to the “Ready to print.” screen, leaving the setting unchanged.

9 Press the ▼ or ▲ key to select “End” and press the Enter key.

● Configuring of each item

1. Paper width

- 1 Press the ▼ or ▲ key to select the desired paper source.
*When the optional roll unit is not installed, "Drawer 1" ["1st paper"] may not be selected.

Inch specifications

Paper width:
1.Drawer 2

Metric specifications

Paper width:
1.2nd paper

- 2 Press the Enter key.

- 3 The selected item will flash. To enable automatic detection, press the ▼ or ▲ key to select "Auto size" and proceed to step 6.

To enter the paper width, select "Input size" and proceed to the next step.

Inch specifications

Drawer 2:
Auto size

Metric specifications

2nd paper:
Auto size

- 4 Press the Enter key.

- 5 Enter a paper width between 17" and 36" (210 mm – 920 mm).

The paper width is entered one digit at a time. Use the ◀ or ▶ key to select a digit and then use the ▼ or ▲ key to enter the desired value.

Inch specifications

input size:
Drawer 2 36.0"

Metric specifications

input size:
2nd paper 920mm

- 6 Press the Enter key. The display will show "set (value) *" and return to the step 1 screen.

- 7 Press the ▼ or ▲ key to select "End" ["back"].

- 8 Press the Enter key. The printer will return to the machine settings screen.

2. Media Type [Pre-set Temp.]

- 1 The selected item will flash. To enable registration of media types for each paper source, press the ▼ or ▲ key to select "ON".

Inch specifications

Media Type:
OFF

Metric specifications

Pre-set Temp.:
OFF

- 2 Press the Enter key. The display will show "set (value) *" and return to machine settings screen.

3. Paper type [Paper material]

NOTE

When "2. Media Type [Pre-set Temp.]" is set to "OFF", this item cannot be set.

- 1 Press the ▼ or ▲ key to select a paper source.
*When the optional roll unit is not installed, "Drawer 1" ["1st paper"] may not be selected.

Inch specifications

Paper type:
2.Drawer 2

Metric specifications

Paper material:
2.2nd paper

- 2 Press the Enter key.

- 3 The selected item will flash. Press the ▼ or ▲ key to select a media type.

Inch specifications

Drawer 2:
Plain

Metric specifications

2nd paper:
Plain

4 Press the Enter key. The display will show “set (value) **” and return to the step 1 screen.

5 Press the ▼ or ▲ key to select “End” [“back”].

6 Press the Enter key. The printer will return to the machine settings screen.

4. Roll end

1 Press the ▼ or ▲ key to select a media type.

Inch specifications

Roll end:
1.Plain

Metric specifications

Roll end:
1.Plain

2 Press the Enter key.

3 The selected item will flash. Select whether the paper’s trailing edge is attached to the roll core by pressing the ▼ or ▲ key to select “Fixed” or “Unfix” [“Unfixed”].

Inch specifications

Plain:
=Unfix<

Metric specifications

Plain:
=Unfixed<

4 Press the Enter key. The display will show “set (value) **” and return to the step 1 screen.

5 Press the ▼ or ▲ key to select “End” [“back”].

6 Press the Enter key. The printer will return to the machine settings screen.

5. Auto shutoff

1 The selected item will flash. Press the ▼ or ▲ key to select the desired auto shutoff mode.

Inch specifications

Auto Shutoff:
=Shutoff mode<

Metric specifications

Auto shutoff:
=Shutoff mode<

2 Press the Enter key. The display will show “set (value) **” and return to machine settings screen.

6. Timer set

NOTE

- If “5. Auto shutoff” is set to “OFF”, the auto shutoff timer cannot be set.
- When setting the auto energy saver time, do not set a longer time than the auto shutoff time. When the auto energy saver time exceeds the auto shutoff time, the auto shutoff function will engage without the auto energy saver function having operated.

1 Press the ▼ or ▲ key to select the function for which the timer is to be set.

Inch specifications

Timer set:
1.Auto pre heat

Metric specifications

Timer set:
1.Auto preheat

2 Press the Enter key.

- 3** Press the ▼ or ▲ key to set the time that elapses before the selected function is activated.

>If "1. Auto preheat" has been selected, set the time to from 5 minutes to 45 minutes.

Inch specifications

```
Auto preheat:
                ≥15min.*
```

Metric specifications

```
Auto preheat:
                ≥15min.*
```

>If "2. Auto shutoff" has been selected, set the time to from 15 minutes to 120 minutes.

Inch specifications

```
Auto Shutoff:
                ≥90min.*
```

Metric specifications

```
Auto Shutoff:
                ≥90min.*
```

- 4** Press the Enter key. The display will show "set (value) **" and return to the step 1 screen.

- 5** Press the ▼ or ▲ key to select "End" ["back"].

- 6** Press the Enter key. The printer will return to the machine settings screen.

7. Size adjustment

- 1** Press the ▼ or ▲ key to select a media type.

Inch specifications

```
Size adjustment:
1.Plain
```

Metric specifications

```
Size adjustment:
1.Plain
```

- 2** Press the Enter key.

- 3** The selected item will flash. Press the ▼ or ▲ key to select the paper length (X).

The value can be set to from -3.0 % to +3.0 %.

Inch specifications

```
Plain:
X≥0.0%* Y 0.0%*
```

Metric specifications

```
Plain:
X≥0.0%* Y 0.0%*
```

- 4** Press the ► key.

- 5** The selected item will flash. Press the ▼ or ▲ key to select the paper width (Y).

The value can be set to from -3.0 % to +3.0 %.

Inch specifications

```
Plain:
X+0.1% Y≥0.0%*
```

Metric specifications

```
Plain:
X+0.1% Y≥0.0%*
```

- 6** Press the Enter key. The display will show "set (value) **" and return to the step 1 screen.

- 7** Press the ▼ or ▲ key to select "End" ["back"].

- 8** Press the Enter key. The printer will return to the machine settings screen.

8. Fusing temp.

1 Press the ▼ or ▲ key to select a media type.

Inch specifications

Fusing temp.:
1.Plain

Metric specifications

Fusing temp.:
1.Plain

2 Press the Enter key.

3 The selected item will flash. Press the ▼ or ▲ key to select the fixing temperature for each media type.

>If "Plain" has been selected, select from 145 °C, 155 °C, and 165 °C.

Inch specifications

Plain:
≥155°C*

Metric specifications

Plain:
≥155°C*

>If "Vellum" has been selected, select from 165 °C, 175 °C, and 185 °C.

>If "Film" has been selected, select from 150 °C, 160 °C, and 170 °C.

>If "Custom" has been selected, the temperature that has been set for the custom media type will be displayed.

4 Press the Enter key. The display will show "set (value) **" and return to the step 1 screen.

5 Press the ▼ or ▲ key to select "End" ["back"].

6 Press the Enter key. The printer will return to the machine settings screen.

9. Custom paper.

1 The selected item will flash. Press the ▼ or ▲ key to select a media type.

Inch specifications

Custom paper:
≥Vellum*

Metric specifications

Custom paper:
≥Vellum*

2 Press the Enter key. The display will show "set (value) **" and return to machine settings screen.

10. Standard size

1 Press the ▼ or ▲ key to select the type of standard size. For an inch specification printer, select "Architecture" or "Engineer". For a metric specification printer, select "A sizes" or "B sizes".

Inch specifications

Standard size:
≥Architecture*

Metric specifications

Standard size:
≥A sizes*

2 Press the Enter key. The display will show "set (value) **" and return to machine settings screen.

11. Auto roll over

- 1** The selected item will flash. To enable auto roll change, press the ▼ or ▲ key to select "ON".

Inch specifications

Auto roll chg: =OFF*

Metric specifications

Auto roll chg: =OFF*

- 2** Press the Enter key. The display will show "set (value) *" and return to machine settings screen.

12. Buzzer

- 1** The selected item will flash. To enable the buzzer press the ▼ or ▲ key to select "ON".

Inch specifications

Buzzer: =ON*

Metric specifications

Buzzer: =ON*

- 2** Press the Enter key. The display will show "set (value) *" and return to machine settings screen.

13. Mgr. code change

- 1** The arrows will flash. Use the ▲▼◀▶ cursor keys to input the pin code

Inch specifications

Mgr. code change: =↑↓←→*

Metric specifications

Mgr. code change: =↑↓←→*

- 2** Press the Enter key. The display will show "set (value) *" and return to machine settings screen.

2. Printer Settings

(1) List of Printer Settings

● Settings common to user/manager

Setting	Description	Selectable values	Default	Page
1. Reset	Resets the printer. Use when rebooting the internal server computer.	-----	-----	4-5
2. Test print	Allows the output a test print using the printer's operation panel.	-----	-----	4-3

● Settings accessible by manager

Setting	Description	Selectable values	Default	Page
3. DHCP server	Toggles the DHCP server ON/OFF. * Configuration of this setting depends on the environment in which the printer will be used. Consult your network administrator in advance.	ON/OFF	ON	3-2
4. IP address	Configures the printer's IP address, Subnet mask, Gateway, and WINS server settings. * Configuration of these settings depends on the environment in which the printer will be used. Consult your network administrator in advance.	-----	0.0.0.0	3-2
5. Subnet mask				
6. Gateway				
7. WINS server				

3. Language Switching

The printer's message can be displayed in "English" (USA), "English", "DEUTSCH" (German), "FRANCAIS" (French), "SPANISH", "ITALIANO" (Italian) and "NEDERLANDS" (Dutch).

- 1 Press the */Menu key.

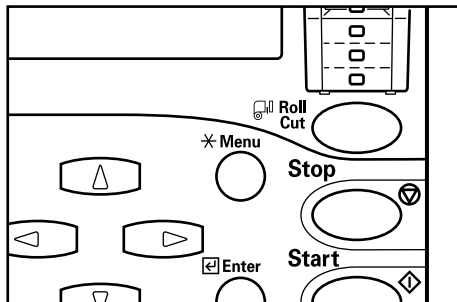

- 2 Press the ▼ or ▲ keys to select "1. Language.".

Inch specifications

Menu:
1. Language.

Metric specifications

Menu:
1. Language.

- 3 Press the Enter key.

- 4 The selected item will flash. Press the ▼ or ▲ key to select the desired language.

Inch specifications

Language:
English(USA)

Metric specifications

Language:
English

- 5 Press the Enter key. The display will show "set (value) **" and return to "Ready to print" screen.

CHAPTER 6 TROUBLESHOOTING

1. If One of These Messages is Displayed...

When any message shown below appears in the message display of the operation panel, follow the appropriate procedure.

Message	Remedy	Page
"Please close. front cover."	The front cover is open. Close the front cover securely.	—
"Please close. eject cover."	The eject cover is open. Close the eject cover securely.	—
"Please close. toner cover."	The toner tank cover is open. Close the toner tank cover securely.	—
"Please close. right cover."	The right cover is open. Close the right cover securely.	—
"Please close. unit."	The main body of the machine is open. Close the machine securely.	—
"Paper misfeed."	A paper jam has occurred. Remove the jammed paper in accordance with the message.	6-7
"Add roll" ["Place paper."]	Paper in the roll unit has run out. Replace the paper roll with a new one.	3-7
"Reverse paper."	Paper in the roll unit has run out. Open the front cover, rewind the remaining paper roll, and replace it with a new one.	3-7
"Close drawer" ["Set drawer."]	A roll unit is not securely inserted. Open the front cover and push the roll unit in securely.	—

CHAPTER 6 TROUBLESHOOTING

Message	Remedy	Page
"Add roll Drawer X XX" ["Set paper. X paper XX mm"] and "Start key to go" are alternately displayed.	The data's page size and the size of the paper roll loaded in the printer do not match. Load the roll for the indicated paper tray. To print from the currently loaded roll, press the Start key. To cancel printing, press the Stop key.	—
"Check waste toner tank."	The waste toner tank is full or the tank is not properly installed. Replace it with a new tank or install the tank properly.	6-5
"Add toner."	When this message is displayed with the "Ready to print" message, printing is possible for a short period of time. However, when only the "Add toner" message is displayed and the Attention indicator on the operation panel is lit, printing is no longer possible. Replenish toner promptly.	6-3
"Call service"	A problem has occurred inside the printer body. See "5. Countermeasures against Call for service Message".	6-6
"Cannot set now."	A function or a default setting that cannot be set now is accessed. See the procedure for configuring the appropriate setting.	—
"Bad code." ["Code incorrect"]	The pin code is incorrect. Use the ▲▼◀▶ cursor keys to input the pin code again.	—

2. Replenishing the Toner

When toner is insufficient the message “Add toner” is displayed. When “Ready to print” is also displayed, printing is possible for a short period of time; however, when the only “Add toner” message is displayed and the Attention indicator on the operation panel is lit, printing is no longer possible. Replenish toner promptly. When several consecutive prints contain large areas of saturated black, large quantities of toner are used at once and the message “Add toner” may be displayed even when a supply of toner remains in the printer. In this case, open and then close the toner replenishing slot. The printer will perform toner replenishment.

Inch specifications

Ready to print.
Add toner.

Metric specifications

Ready to print.
Add toner.

- 1 Turn the screws on both sides of the toner replenishing slot and align them as shown to open the toner replenishing slot.

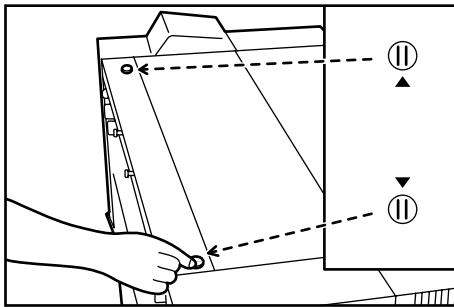

- 2 Grasp the replenishment toner bottle upside down and tap the bottom of the bottle 10 times.

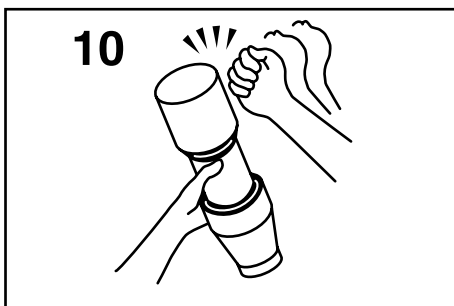

⚠ CAUTION

DO NOT attempt to incinerate the toner containers or the waste toner tank. Dangerous sparks may cause burns.

⚠ CAUTION

DO NOT attempt to force open or destroy the toner containers or the waste toner tank.

- 3 Shake the replenishment toner bottle up and down 10 times, and grasp it horizontally and shake it side to side 10 times.

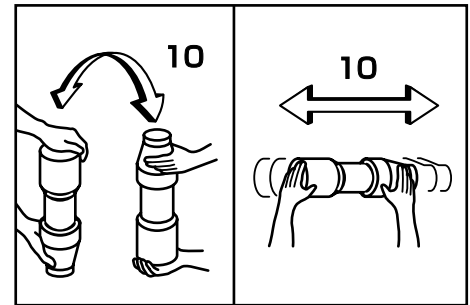

- 4 Align the ▼ portion of the toner bottle with the pin ① (metal protrusion) of the opening to insert the bottle as shown in the illustration.

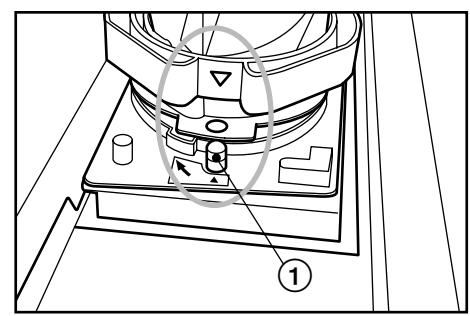

CHAPTER 6 TROUBLESHOOTING

- 5** While pressing the toner bottle down, turn it clockwise 90 degrees to replenish the toner.

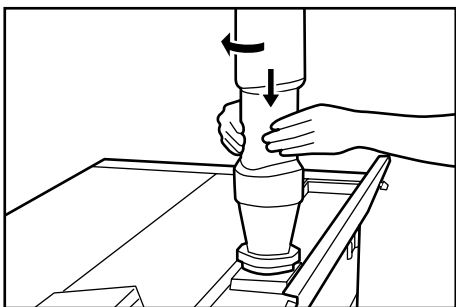

● After use, ALWAYS dispose of the toner containers and the waste toner tank in accordance with Federal, State and Local rules and regulations.

- 6** Tap the side of the toner bottle 10 times to loosen any remaining toner.

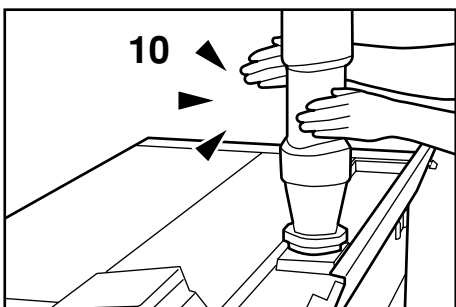

- 7** Press the toner bottle down, turn it to the original position and gently remove it.

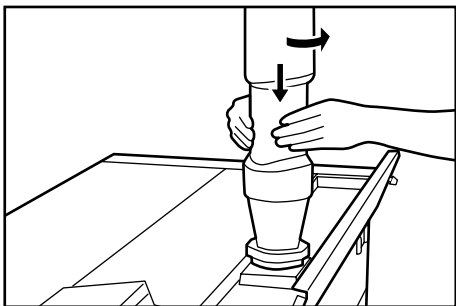

- 8** Close the toner replenishing slot and turn the toner replenishing slot screws to the location shown in the illustration to secure the cover.

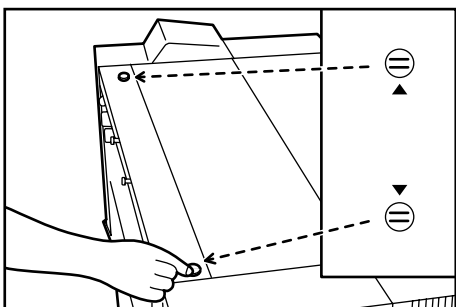

3. Replacing the Waste Toner Tank

When the waste toner tank becomes full the message “Check waste toner tank” is displayed. Since the Attention indicator on the operation panel will be lit and printing will be disabled, replace the waste toner tank with a new tank.

Inch specifications

Check waste toner tank.

Metric specifications

Check waste toner tank.

- 1 Open the right cover and remove the waste toner tank by pulling it out toward you.

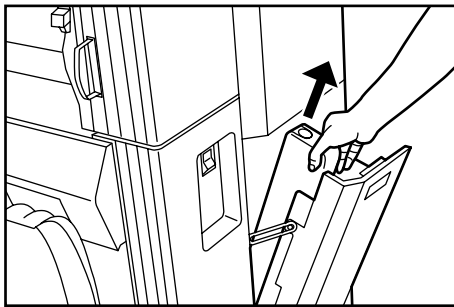

- 2 Seal the waste toner tank opening with the seal located on it.

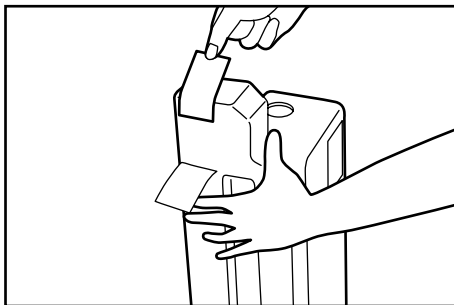

- 3 Insert a new waste toner tank into the machine.

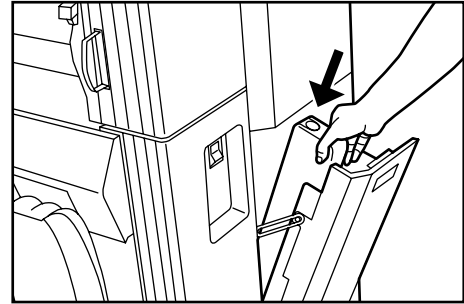

- 4 Close the right cover.
*Toner in the waste toner tank cannot be reused.

● After use, ALWAYS dispose of the toner containers and the waste toner tank in accordance with Federal, State and Local rules and regulations.



CAUTION

DO NOT attempt to incinerate the toner containers or the waste toner tank. Dangerous sparks may cause burns.



CAUTION

DO NOT attempt to force open or destroy the toner containers or the waste toner tank.

4. Countermeasures against Call for service Message

When a service call message such as the following is displayed and the Attention indicator on the operation panel is lit, the printer has detected a malfunction. Stop use of the printer and perform the following procedure.

Inch specifications

Call service CXXXX

Error Occurred. CXXXX

Metric specifications

Call service CXXXX

Error occurred. CXXXX

- 1** Pull the main body release lever to open and then close the printer body.

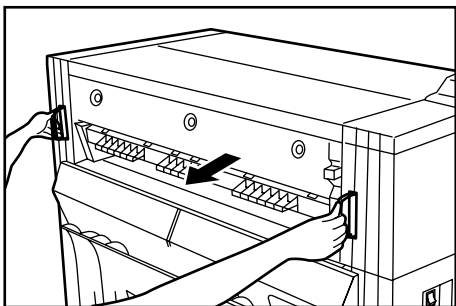

- 2** If the same message remains, make a note of the displayed error code (C xxxx in the example above).

- 3** Turn the main switch off () and disconnect the power cord.

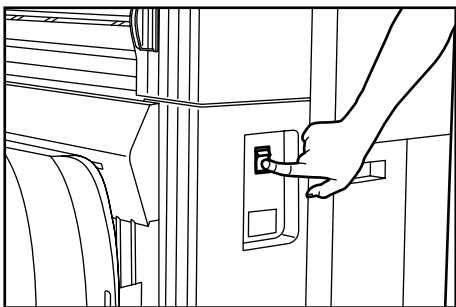

- 4** Contact your service representative and report the error code above.

5. When Paper Jams

When there is a paper jam, the printer stops operation and a paper jam message is displayed. The Attention indicator and the paper jam location indicator on the operation panel will also be lit. With the main switch ON (I), refer to the display and clear the jammed paper.

(1) Jam Location Display

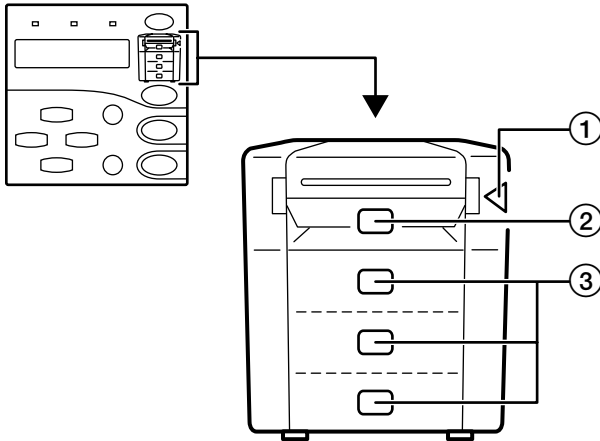

- ① Jam in the printer
- ② Jam in the bypass slot (Page 6-9)
- ③ Jam in the paper feed section (Page 6-9)

(2) Cautions

WARNING

High voltage is present in the charger section. Take sufficient care when working in this area, as there is a danger of electrical shock.

CAUTION

The printer's fixing unit is extremely hot. Take sufficient care when working in this area, as there is a danger of getting burned.

- Do not reuse paper which has jammed in the printer.
- Take care not to leave shreds of paper inside the printer when removing jammed paper that has become ripped or torn. Such shreds may cause additional paper jams.
- Once the jam has been removed, the printer will start to warm up and the paper jam message will be cleared, returning the printer to its state before the jam occurred.

(3) Removal Procedure

- ① If "Paper misfeed. Press cut key." or "Paper misfeed. Open Fuser unit." ["Paper misfeed. Open fuse unit."] appears:

Inch specifications

Paper misfeed.
Press cut key.

Paper misfeed.
Open Fuser unit.

Metric specifications

Paper misfeed.
Press cut key.

Paper misfeed.
Open fuse unit.

Paper has jammed in the printer. Perform the following procedure to remove the jammed paper.

- 1** If "Press cut key." appears, press the Roll Cut key.

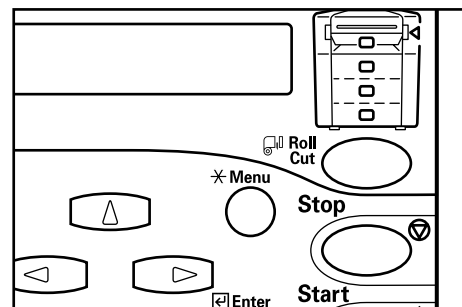

IMPORTANT

Do not open any cover before pressing the Roll Cut key.

- 2** Grasp the printer body release lever and pull it toward you. The printer body will be opened.

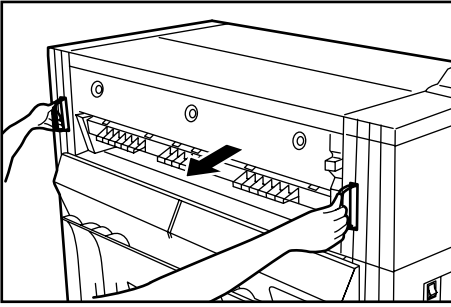

WARNING

High voltage is present in the charger section. Take sufficient care when working in this area, as there is a danger of electrical shock.

CAUTION

The printer's fixing unit is extremely hot. Take sufficient care when working in this area, as there is a danger of getting burned.

- 3** If the jammed paper is present, pull it out.
* If it is difficult to pull it out, do not pull too hard but simply proceed to the next step.

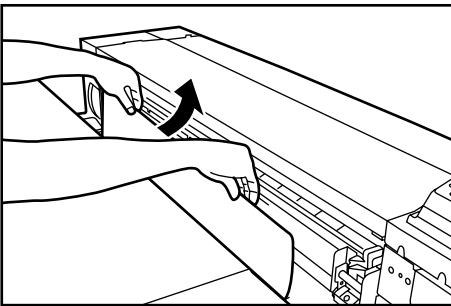

- 4** Turn the transport knob counterclockwise to feed the jammed paper.



- 5** If the paper is present, remove it from inside the printer.

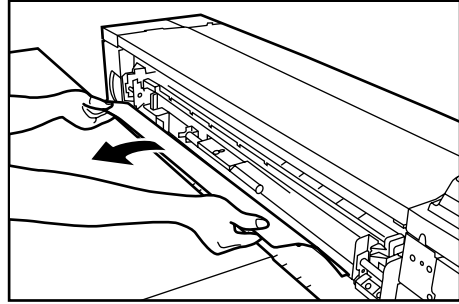

- 6** Push the ejection release lever toward you. The ejection cover will be opened.

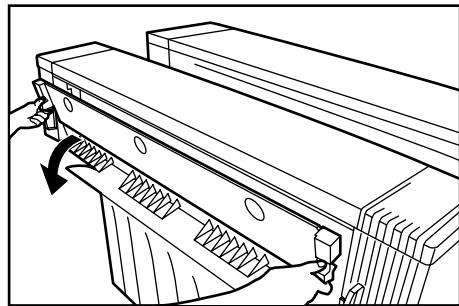

CAUTION

The printer's fixing unit is extremely hot. Take sufficient care when working in this area, as there is a danger of getting burned.

- 7** Remove the jammed paper.

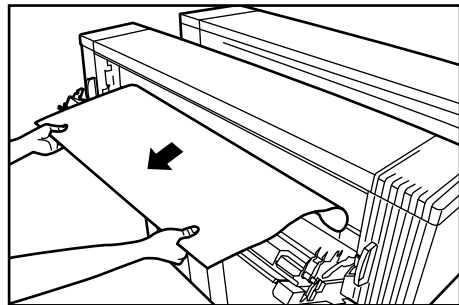

IMPORTANT

When opening the ejection cover, be sure to pull out the original table in advance.

7 Close the ejection cover.

8 Close the printer securely.

② If “Paper misfeed. Remove paper.” appears:

Inch specifications

Paper misfeed.
Remove paper.

Metric specifications

Paper misfeed.
Remove paper.

Paper has jammed in the bypass slot. Perform the following procedure to remove the jammed paper.

1 Pull out the paper jammed in the bypass slot.
* If the jammed paper is difficult to remove, do not pull too hard but simply proceed to the next step.

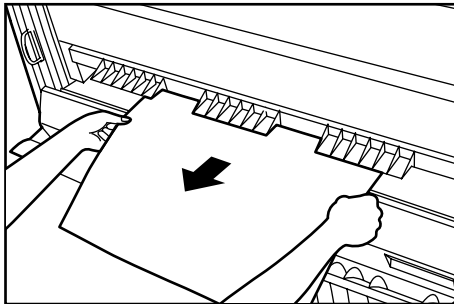

2 Grasp the printer body release lever and pull it toward you. The printer body will be opened.

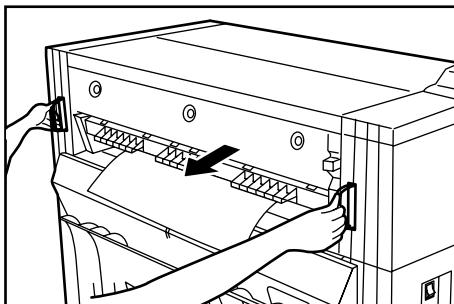

3 If the paper is present, remove it from inside the printer.

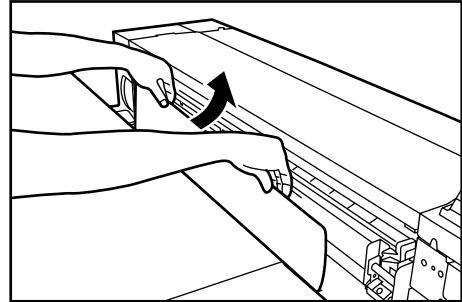

4 Close the printer securely.

③ If “Paper misfeed. Open front cover” appears:

Inch specifications

Paper misfeed.
Open front cover

Metric specifications

Paper misfeed.
Open front cover

The paper roll has jammed in the indicated paper source. Perform the following procedure to remove the jammed paper.

1 Open the front cover.

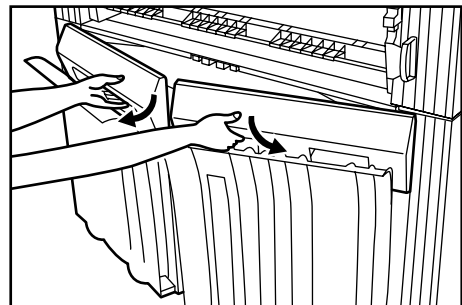

! WARNING

High voltage is present in the charger section. Take sufficient care when working in this area, as there is a danger of electrical shock.

CHAPTER 6 TROUBLESHOOTING

- 2** Grasp the handles (A) of the roll unit to unlock the unit and pull out the roll unit until it stops.

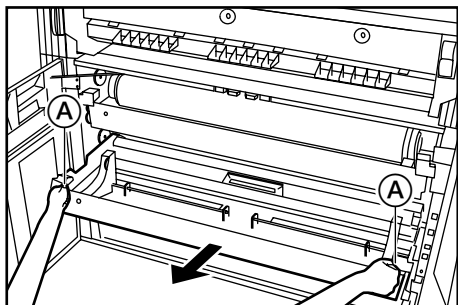

- 3** Grasp the flange and rewind the paper roll.

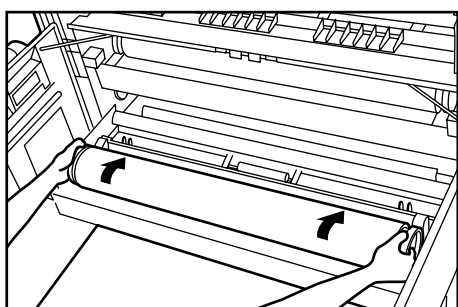

- 4** If there is any wrinkled or folded area, remove it with a cutting knife or scissors.

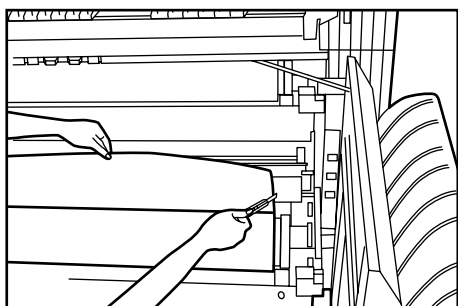

- 5** Grasp both of the paper roll insertion latches (3) and open the paper roll insertion cover (4).

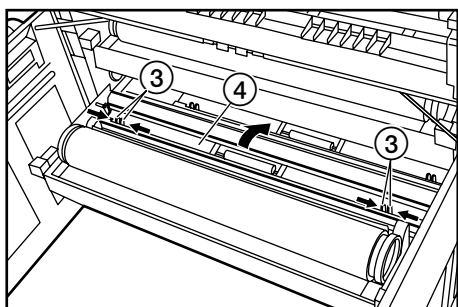

- 6** Insert the leading edge of the paper under the paper roll insertion guide and advance the edge past the guide approximately 1/2" [10 mm] as shown in the illustration.

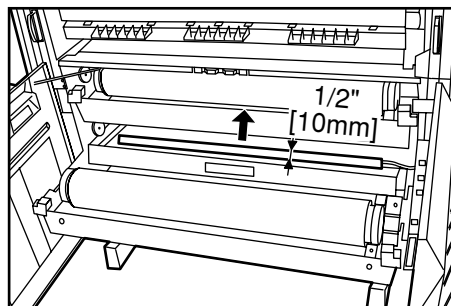

- 7** Grasp both of the paper roll insertion latches and close the paper roll insertion cover.

IMPORTANT

If the paper roll that has been loaded has slackened, grasp the flange and wind the paper roll to remove the slack. If not, the paper may be fed obliquely.

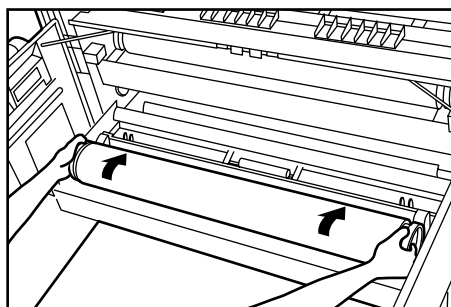

- 8** Push the roll unit securely back into the machine.

- 9** Close the front cover.

- 10** If the leading edge of the paper is not cut straight, press the Roll Cut key. The leading edge of the paper will be cut.

6. Troubleshooting

Refer to the following chart if trouble occurs. If trouble persists, contact your service representative.

TROUBLE	CHECK POINT	PROCEDURE	PAGE
The main switch is on but nothing is displayed on the operation panel.	Is the power cord connected properly?	Make sure that the power cord is securely inserted into an outlet.	—
Nothing is being printed out	Is the power cord connected properly?	Make sure that the power cord is securely inserted into an outlet.	—
	Is the main switch to the printer turned ON?	Make sure that the main switch is turned ON ().	3-2
	Is the network cable appropriate and is it connected properly?	Make sure that an appropriate network cable is being used and make sure that it is connected properly.	3-2
	Was the network cable connected AFTER the power to the printer was turned ON?	Always connect the printer cable BEFORE turning the power to the printer ON.	—
	Is the printer off-line? (Is "Off line." displayed?)	Press the On Line key in order to put the printer back on-line. Once it is back on-line, the Ready indicator will light.	2-4
	Was printing initiated immediately after the main switch was turned ON () to the printer?	Even though the printer's warm-up may have been completed, the internal computer that manages printing and scanning may still be starting up. Wait approximately 2 minutes or so and try again.	—
	Are the IP addresses for the printer and/or the corresponding computer (device) name and host name correctly registered in your computer?	Make sure that the settings in the printer driver and/or the software application being used are correct.	—

CHAPTER 6 TROUBLESHOOTING

TROUBLE	CHECK POINT	PROCEDURE	PAGE
Paper jams often.	Are there wrinkles or folds in the paper?	Remove the portion of the paper roll that contains the wrinkles or folds.	—
	Is there any jammed paper or are there other pieces of paper remaining inside the machine?	Remove them by following the appropriate procedure.	6-7
	Is the paper setting method proper?	Check the paper setting method.	3-7
	Is vellum being used?	The leading edge may have been damaged. Pull out the paper roll until the damaged portion comes out and then cut it before use.	—
The printed image is shifted to either side (widthwise).	Is the paper roll properly installed into the roll unit?	Align the flange guide positions with the appropriate size labels.	3-7
	Was the paper fed properly in bypass mode?	Adjust the bypass guides to the paper size and then insert the paper.	4-2
Paper is wrinkled or curled.	Is the media type setting correct?	Select the appropriate media type for the media type setting.	5-6
	Is the paper wet?	Replace the paper roll with a new one. Depending on the operating environment, turn the dew prevention heater switch on.	3-7 3-9
	Is the roll unit flange set properly?	Set the roll unit flange properly.	3-7
	Is the fixing temperature proper?	Adjust the fixing temperature to a lower temperature.	5-9
Toner does not adhere well to the paper.	Is the media type setting correct?	Select the appropriate media type for the media type setting.	5-6
	Was thick paper used?	Adjust the fixing temperature to a higher temperature.	5-9

TROUBLE	CHECK POINT	PROCEDURE	PAGE
Film is sticky with ink after printing.	Is film selected as the media type?	Select film for the media type setting.	5-6
Film curls after printing.	Is film selected as the media type?	Select film for the media type setting.	5-6
	Is the fixing temperature proper?	Adjust the fixing temperature to a lower temperature.	5-9
The print data and the printed image differ in size.	Is the media type setting correct?	Select the appropriate media type for the media type setting.	5-6
	Was the size adjusted?	Adjust the size.	5-8
The printed image is light.	Is the message indicating toner replenishment displayed?	Replenish toner.	6-3
	Is the paper wet?	Replace the paper roll with a new one. Depending on the operating environment, turn the dew prevention heater switch on.	3-7 3-9
Text is not being printed correctly.	Is the network cable appropriate and is it connected properly?	Make sure that an appropriate network cable is being used and make sure that it is connected properly.	—
Print out is not correct.	Is your computer configured correctly?	Make sure that the settings in the software application being used are correct.	—

CHAPTER 7 SPECIFICATIONS

<Hardware>

Type	Console
Printing system	Indirect electrostatic
Compatible Print Sizes	Maximum: 36" x 48" 36" (W) x 237" (L) [A0 920 mm (W) x 6000 mm (L)] Minimum: 8 1/2" x 11" 8 1/2" (W) x 11" (L) [A4 (portrait) 210 mm (W) x 297 mm (L)] Thickness: 64 to 80 g/m ² Void Area: Leading/trailing edge of paper: 10 mm or less, right/left edge of paper: 3 mm or less
Print speed	2.6 ppm printer: 2.6 sheets/minute for 36" x 48" [A0], 4 sheets/minute for 36" x 24" [A1] 3 ppm printer: 3 sheets/minute for 36" x 48" [A0], 6 sheets/minute for 36" x 24" [A1]
Warm up time	Within 600 seconds (Room temperature 68 °F/20 °C, Humidity 65 %RH)
Interface	One 100BASE-TX (or 10BASE-T) port
Memory	2.6 ppm printer: 128 MB as standard 3 ppm printer: 256 MB as standard
Paper feed system	Two roll units and bypass
Compatible print media	Standard paper (64 to 80 g/m ²), vellum, film
Writing system	LED
Resolution	600 dpi x 600 dpi
Developing system	Dry
Toner supply system	Bottle cartridge system
Fixing system	Heat roller
Cleaning system	Blade and fur brush
Photoconductor	OPC (with dew prevention heater)
Features	Size adjustment, fixing temperature, energy saver, auto shutoff, self-diagnosis
Power source	120 V AC, 60 Hz, 14 A 230 V AC, 50 Hz, 7 A
Power consumption	1680 W (120 V) 1610 W (230 V)
Dimensions	52 3/8" (W) x 27 11/16" (D) x 43 1/8" (H) [1330 mm (W) x 704 mm (D) x 1095 mm (H)]
Installation dimensions	53 3/4" (W) x 30 1/2" (D) [1366 mm (W) x 774 mm (D)]
Weight	Approx. 523.6 lbs. [Approx. 238 kg]
Noise emission	≤70 db (A)
Accessories	Flanges, flange handle, bypass guide, and CD-ROM
Options	Roll unit, scanner unit, and key counter

(Specifications are subject to change without notice.)

CHAPTER 7 SPECIFICATIONS

<Software Operating Environment>

● Printer drivers

		IBM PC-AT or compatible				
OS		Windows 95 (OSR2)	Windows 98	Windows Me	Windows NT 4.0 (with Service Pack 5 or later installed)	Windows 2000
Minimum configuration	CPU	i486DX2 66MHz		Pentium 150MHz	i486DX2 66MHz	Pentium 166MHz
	RAM	8MB	16MB	32MB	16MB	24MB
	Free hard disk space	10MB				
Recommended configuration	CPU	Celeron 266MHz or faster				Pentium II 300MHz or faster
	RAM	128MB or more				
	Free hard disk space	300MB				
CD-ROM drive		One drive				
Printer Port		One 100BASE-T or 10BASE-T port				

		Macintosh	
Mac OS		Mac OS 8.6 - 9.1	
Minimum configuration	CPU	PowerPC	
	RAM	24MB	
	Free hard disk space	10MB	
Recommended configuration	CPU	PowerPC 604 200MHz or faster	
	RAM	64MB or more	
	Free hard disk space	10MB	
CD-ROM drive		One drive	
Printer Port		One 100BASE-T or 10BASE-T port	

● **Print Utility (recommended operating environment)**

	IBM PC-AT or compatible				
OS	Windows 95 (OSR2)	Windows 98	Windows Me	Windows NT 4.0 (with Service Pack 5 or later installed)	Windows 2000
CPU	Pentium 200MHz or faster				Pentium II 300MHz or faster
RAM	64MB or more		128MB or more		
Free hard disk space	100MB				
CD-ROM drive	One drive				
Printer Port	One 100BASE-T or 10BASE-T port				

CAUTION!

The power plug is the main isolation device! Other switches on the equipment are only functional switches and are not suitable for isolating the equipment from the power source.

ATTENTION !

Le débranchement de la fiche secteur est le seul moyen de mettre l'appareil hors tension. Les interrupteurs sur l'appareil ne sont que des interrupteurs de fonctionnement : ils ne mettent pas l'appareil hors tension.

WARNING

This equipment has been tested and found to comply with the limits for a Class A digital device, pursuant to Part 15 of the FCC Rules. These limits are designed to provide reasonable protection against harmful interference when the equipment is operated in a commercial environment. This equipment generates, uses, and can radiate radio frequency energy and, if not installed and used in accordance with the instruction manual, may cause harmful interference to radio communications. Operation of this equipment in a residential area is likely to cause harmful interference in which case the user will be required to correct the interference at his own expense.

CAUTION – The changes or modifications not expressly approved by the party responsible for compliance could void the user's authority to operate the equipment.

* The above warning is valid only in the United States of America.

NEW PRINTER LIMITED WARRANTY

KYOCERA MITA warrants your plain paper printer against any defects in material and workmanship for a period of 90 days from the date of installation by an Authorized KYOCERA MITA Dealer. In the event your printer is found to be defective within the warranty period, KYOCERA MITA's only obligation and your exclusive remedy shall be replacement of any defective parts. It is understood that KYOCERA MITA shall have no obligation to furnish labor. Photo conductors, lamps and other consumable products are specifically excluded from this warranty. The warranty on the photo conductor is limited to proper performance at the time of installation.

This warranty is valid only as to the original retail purchaser.

In order to obtain performance of this warranty, the original retail purchaser must immediately notify the Authorized KYOCERA MITA Dealer from whom the printer was purchased of the defects. If the KYOCERA MITA dealer is not able to provide warranty service, write to KYOCERA MITA at the below address, for the name and address of an Authorized KYOCERA MITA Dealer in your area.

KYOCERA MITA AMERICA, INC.

225. Sand Road. P. O. Box 40008. Fairfield.
New Jersey 07004-0008. U. S. A.

This warranty does not cover printers ; a) which have become damaged due to operator negligence, misuse or accidents ; b) which do not work properly because of the use of supplies not meeting KYOCERA MITA's specifications ; c) which have been serviced by a technician not employed by KYOCERA MITA, or an Authorized KYOCERA MITA Dealer ; or d) which have had the serial number modified, altered or removed.

This warranty gives you specific legal rights. You may also have other rights which vary from state to state, or province to province.

THIS WARRANTY IS MADE IN LIEU OF ALL OTHER WARRANTIES, EXPRESS OR IMPLIED, AND KYOCERA MITA SPECIFICALLY DISCLAIMS ANY IMPLIED WARRANTY OF MERCHANTABILITY AND FITNESS FOR A PARTICULAR PURPOSE. THIS WARRANTY SHALL NOT EXTEND TO ANY INCIDENTAL OR CONSEQUENTIAL DAMAGE WHICH MAY ARISE OUT OF THE USE OR INABILITY TO USE THE PRINTER.

KYOCERA MITA CANADA, LTD.

6120 Kestrel Road.
Mississauga. Ontario L5T 1S8

*** For best print results and machine performance, we recommend that you use only KYOCERA MITA original supplies for your KYOCERA MITA products.**



KYOCERA MITA AMERICA, INC.

Headquarters:

225 Sand Road, P.O. Box 40008
Fairfield, New Jersey 07004-0008
TEL : (973) 808-8444
FAX : (973) 882-6000

New York Show Room:

149 West 51st street,
New York, NY 10019
TEL : (212) 554-2679
FAX : (212) 554-2625

Northeastern Region:

225 Sand Road, P.O. Box 40008
Fairfield, New Jersey 07004-0008
TEL : (973) 808-8444
FAX : (973) 882-4401

Midwestern Region:

201 Hansen Court Suite 119
Wood Dale, Illinois 60179
TEL : (630) 238-9982
FAX : (630) 238-9487

Western Region:

14101 Alton Parkway,
Irvine, California 92618-7006
TEL : (949) 457-9000
FAX : (949) 457-9119

Southeastern Region:

1500 Oakbrook Drive,
Norcross, Georgia 30093
TEL : (770) 729-9786
FAX : (770) 729-9873

Southwestern Region:

2825 West Story Road,
Irving, Texas 75038-5299
TEL : (972) 550-8987
FAX : (972) 570-4704

Dallas Parts Distribution Center & National Training Center:

2825 West Story Road,
Irving, Texas 75038-5299
TEL : (972) 659-0055
FAX : (972) 570-5816

KYOCERA MITA CANADA, LTD.

6120 Kestrel Road, Mississauga,
Ontario L5T 1S8, Canada
TEL : (905) 670-4425
FAX : (905) 670-8116

KYOCERA MITA MEXICO, S.A. DE C.V.

Av. 16 de Septiembre #407
Col. Santa Inés,
02130 Azcapotzalco
México, D.F. Mexico
TEL : (5) 383-2741
FAX : (5) 383-7804